

Microcontroller Based Electronic Digital Lock with Security Notification

Musa Baba Lawan^{1*}, Ya'u Alhaji Samaila¹ and Ibrahim Tijjani¹

¹*Department of Electrical and Electronics Engineering, University of Maiduguri, Maiduguri, Nigeria.*

Original Research Article

ABSTRACT

Due to the advancement in science and technology all over the world, there is a significant increase in the rate of crime and sophistication in crimes; as a result, it is necessary to ensure the security of one's self and one's valuable belongings. The main goal of this paper is aimed at creating an electronic security system capable of detecting an intruder and reporting to security personnel. The design of the microcontroller based electronic digital lock with security notification uses a four-digit pass key for its operation. The operation involves opening the door, closing the door, changing of password and alarm upon wrong password entry. It is important for use in Bank Vaults, Hotels, Offices and can also be used in our homes. The research objectives were achieved with the use of microcontroller which programs the ATMEGA328P microprocessor and interfaces it with all the other components in the circuit. In the end, the circuit was able to activate the relay switches for opening and closing the door in about three seconds, and the alarm sounds when it detects a wrong password. Comparison was made between the conventional traditional lock system and the proposed one. The distinctive feature added is the sliding door, the security notification feature and the password modification in case of a breach in security. The design fulfills the requirements of supporting conventional lock systems eliminating the use of ordinary keys

*Corresponding author: Email: babalawan24@unimaid.edu.ng;

shared among occupants. To demonstrate and evaluate the design, a prototype was developed. As compared to other microcontroller based digital lock, it is easy and it required less hardware. It doesn't need additional A/D and D/A converter. We can set the password and reset it without using external device and can be easily implemented. The evaluation shows that the design works well, consumes minimal power and is able to unlock a door. Atmega328p Microcontroller was used as the main component of the project.

Keywords: Arduino; digital lock; keypad interfacing; LCD; microcontroller.

1. INTRODUCTION

1.1 Background

The protection of lives and properties of every individual is of high priority. The research was carried out, and the statistics found that intruders easily break almost 80% of mechanical security lock systems used by individuals. Security has been a man's concern and needs right from the inception of time. Olden day's security system was mechanical, plain wall or just a wall with a watchdog. The main reason for providing locks for homes, offices, churches, schools and other buildings is for safety of lives and property [1].

Digital computers are not only used to calculate data, processing data and game playing alone, but also are being used to monitor and control all kinds of individual processes and machine works such as robots, printing machine, rolling mills, aircraft, etc. Microcontroller which is a small and tiny computer designed to perform some specific tasks is one of the prominent embedded system used. The basic idea of microcontroller is to assemble all the input and output peripherals in one simple circuit, contrary to a large and sophisticated computer with a microprocessor and large numbers of peripherals [2].

A smart home design application that allows the owner to manage his/her home through the internet was proposed [3]. It uses a PC as a server which increases the price and power consumption. Others need web page hosting that incurs extra cost. The author concluded that the use of PC requires considerable cost and can be reduced by using a microcontroller. Password based door locking system using microcontroller was proposed [4]. The main component in the circuit is 8051 microcontroller. The concept behind this project is of a door-latch opening using a password. A micro-controller based Digital Code Lock that serves the purpose of security was created [5]. The system comprises of a push button keypad connected to the 8 bit microcontroller ATmega328P. It allows you to

preset a password. The lock will open if the entered password matches the preset one. If the entered password is wrong, a buzzer will be activated. A design of a digital combination lock system which investigates a finite state machine based combination (Digital) lock using several modules. Both combinational and sequential circuitry, using Verilog coding and simulated in Xilinx ISE 14.2 [6]. In this design, the main part is the Finite State Machine (FSM) based controller. The function of that controller is to detect when a user has entered the 4 digit secret code. Now a FSM is basically a sequential circuit which follows pre-user-defined number states to control a number of inputs, where each and every state is a stable entity that it can occupy. It consists of a next state decoder, memory flip-flops and output decoder. Wei and Yanping [7] Designed a small, low cost, functional and practical AT89C52 microcontroller-based electronic lock design. The locks to AT89C52 microcontroller as the core mainly composed of the microcontroller, LED, digital tubes and relays. And through the C programming language, complete the functions of unlock password, prompt an error, LED display and timing, and even to achieve a function that when power is down the lock can remember the passwords.

Atmega328 microcontroller was used as the main component in the research. Every component used is directly or indirectly connected to the microcontroller. The codes for the display unit, the keypad unit, setting and resetting of the password are all stored in the microcontroller. The codes are programmed and compiled in the Arduino compiler, then uploaded to the microcontroller via a universal serial bus (USB) cable. The microcontroller is installed on the board and every component on the circuit is attached to the microcontroller. The lock was designed in such a way that if any wrong key is pressed in the process of inputting the password, it resets itself automatically, thereby sending a distress signal to a security post which will let the security know that an intruder is accessing the system. As compared to other microcontroller

based digital lock it is easy and it required less hardware. It doesn't need addition Analogue/digital and Digital/Analogue converter. Also, another distinctive feature added is the sliding door and the security notification. The evaluation shows that the design works well, consumes minimal power from the hardware and can unlock a door. The reset system makes it difficult or impossible to break.

2. METHODOLOGY

2.1 System Hardware Components

This section presents the architectural components of the Microcontroller based electronic digital lock system and the detail of their functions.

2.1.1 Arduino-Uno Board

Arduino is an open-source electronics platform based on easy-to-use hardware and software. Arduino boards can read inputs - light on a sensor, a finger on a button, or a Twitter message - and turn it into an output - activating a motor. Arduino Uno is a microcontroller board based on the ATmega328P (datasheet) as shown in Fig. 1. It has 14 digital input/output pins (of which 6 can be used as PWM outputs), 6 analogue inputs, a 16 MHz quartz crystal, a USB connection, a power jack, an ICSP header and a reset button. It contains everything needed to support the microcontroller. Simply connect it to a computer with a USB cable or power it with an AC-to-DC adapter or battery to get started [8]. The Uno differs from all preceding boards in that it does not use the FTDI USB-to-serial driver chip. Instead, it features the Atmega16U2/Atmega8U2 up to version R2) programmed as a USB-to-serial converter.

Microcontroller (MCU) is determined by the following criteria [9][10]:

- 1) The size of the flash memory.
- 2) The types of the contained memory FLASH, EEPROM or ROM.
- 3) The interfaces it support RS232, Ethernet, USB or other interfaces.
- 4) The size of the MCU layout on the PCB.
- 5) The low cost of MCU.
- 6) The clock cycle (fast speed processing).

2.1.2 Intelligent LCDs

The Ability to display letters, words, and all manner of symbols, not just numbers, easily

programmable makes LCD better than familiar 7-segment LED. There are many types of LCD according to its functionality and varies in Characters length and lines. Most LCD modules conform to a standard interface specification [11]. The LCD is of different types and dimensions, with the 16x2 LM016L being the basic module and the most used in many electronic devices and circuits. A 16x2 LCD can display 16 characters per line and there are two such lines in the display unit as shown in Fig. 2. Each character is displayed in a 5x7 pixel matrix. The LCD has two registers, namely; command and data. The command register stores the command given to the LCD. A command is an instruction given to the LCD to perform a predefined task, like initialising it, clearing the screen, setting the cursor position, controlling display, etc. while the data register stores the data to be displayed on the LCD screen. The data is the ASCII value of the character to be displayed on the LCD.



Fig. 1. Arduino-uno board

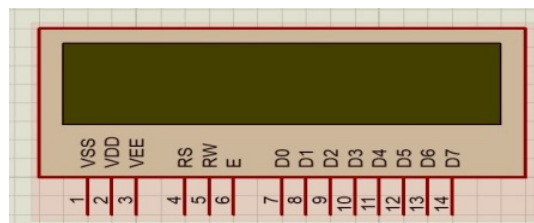

Fig. 2. 16x2 LM016L LCD

2.1.2 Keypad Interfacing with Arduino-Uno.

In this lock system, a 4*4 (16) keypad will be interfaced with the Arduino-Uno. It is known that keypad is one of the most important input devices used in electronic engineering. Keypad is the easiest and cheapest way to give a command or instruction to an electronic device or system. Whenever a key is pressed in a keypad

module, the Arduino-Uno detects it and show the corresponding key on the 16*2 liquid crystal display (LCD).See Fig. 3.



Fig. 3. Keypad Interface with the microcontroller

There are three techniques of keypad interface [12]:

- i. Scanning technique
- ii. An external electronic design.
- iii. Using keypad encoder IC

2.2 Design of the Electronic Digital Lock

The block diagram of the electronic digital lock with security notification is as shown in the Fig. 4. The power supply feeds the circuit with a 12V direct current (d.c), which enables the operation of the whole components of the circuit. The display unit is a 16*2 liquid crystal display (LCD), which enables the user to have a smooth interaction with the digital door by reading and following instructions on the screen. The keypad unit serves as an input unit of the digital lock, it enables the user to access the lock using the four digit password, and also to set and reset a new password. The control unit is the microprocessor. It is the brain of the project, and every bit of data goes through the processor for execution. It is responsible for every action of the digital door, as it holds the codes for the lock operation. The control unit receives data from the keypad unit and sends it for display on the LCD screen. It also recognises a correct password entered by sending a signal to the relay switch which opens the door via a motor or sends distress signal to the buzzer in case of an intrusion. The switching unit consists of two relay switches, one for opening and another for closing the door. The relay switches receives 5V signal from the microprocessor. The alarm unit consists

of a buzzer which sounds when a key is pressed and also makes an alarm when a wrong key combination is entered. The load unit consists of a 5V dc motor for opening and closing of the door. The motor receives its signal from the relay switch, slides the door open for 4 seconds and then close the door.

2.2.1 Design of the power supply unit

Every electrical and electronic device that we use in our day-to-day life requires a power supply. In general, we use an AC supply of 230V 50Hz, but the microcontroller requires a 5V DC supply, so the AC 230V needs to be converted into 5V DC using the step-down converter of the power supply circuit. The output voltage required for the operation of this project is DC voltage. The power supply circuit is shown in Fig. 5.

Transformer rating is 230/12V step-down transformer

Please arrange ref. serially after ref. [12]

The voltage and current ratings are given in root mean square (RMS)

$$V_{rms} = 12V$$

$$I_{rms} = 500mA$$

The peak voltage of the transformer is given by equation (1):

$$V_{peak} = V_{rms} \times \sqrt{2} \quad (1)$$

$$V_{peak} = 16.97V$$

The peak current of the transformer is calculated as follows:

$$I_{peak} = I_{rms} \times \sqrt{2} \quad (2)$$

$$I_{peak} = 500mA \times \sqrt{2}$$

$$I_{peak} = 707.11mA$$

The expected load resistance R_L of the circuit is given by:

$$R_L = V_{peak} / I_{peak} \quad (3)$$

$$R_L = 16.97 / 707 \times 10^{-3}$$

$$R_L = 24\Omega$$

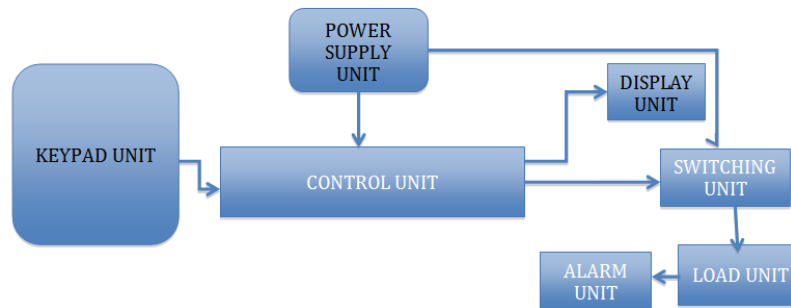

Fig. 4. Block diagram of the electronic digital lock with security notification

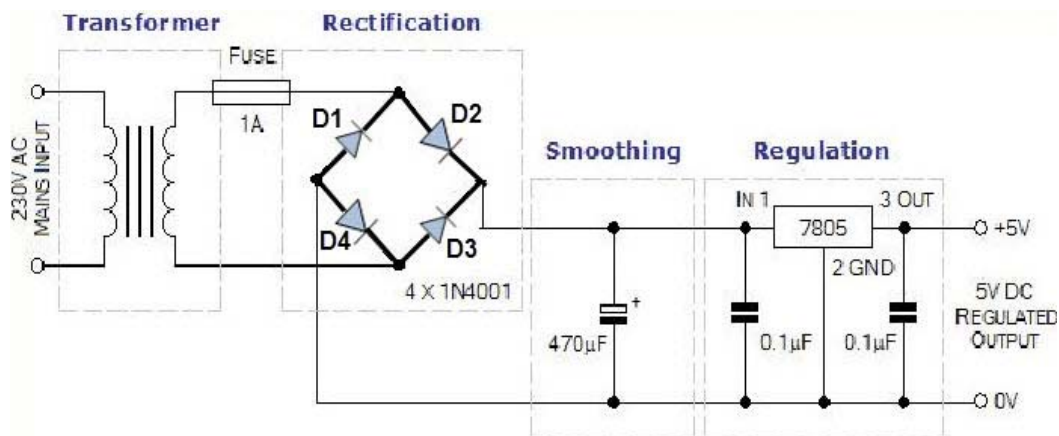

Fig. 5. Circuit diagram of the power supply

In order to power the Atmega328p Microcontroller with the 5V DC supply, the LM 7805 voltage regulator was used; the expression for the voltage regulator is given below.

$$V_{in} = V_{out} + 2 \quad (4)$$

$$V_{in} = 5 + 2$$

$$V_{in} = 7V$$

This indicates that the minimum input that the LM7805 would require to constantly supply 5V power to the microcontroller is 7V, but the V_{dc} obtained is 9.4V, this is an enough voltage for the LM7805 voltage regulator to power the circuit.

2.2.2 Microcontroller Board

The Microcontroller has 14 digital input/output pins, 6 analogue inputs, A16 MHz ceramic resonator, A USB connection, a power jack, An ICSP header and a reset button.

Power Pins [15]

V_{in}: The input voltage to the Arduino Uno board when it's using an external power source is 9V (as opposed to 5 volts from the USB connection or other regulated power source). You can supply voltage through this pin, or, if supplying voltage via the power jack, access it through this pin.

5V: The regulated power supply used to power the microcontroller and other components on the board. This can come either from VIN via an on-board regulator, or be supplied by USB or another regulated 5V supply.

3V3: A 3.3-volt supply generated by the on-board regulator. Maximum current draw is 50 mA.

GND: Ground pins.

2.2.3 Design of LCD display unit

The LCD display unit is made up of a 16 × 2 LCD display and a 10k variable resistor, as shown in Fig. 6. The 10kΩ variable resistor (V_R) is used to

set the contrast of the LCD display, and this is set to 2/3 of the supply voltage, that is given by;

$$V_R = 10k\Omega$$

Set resistance

$$R_s = 10 \times \frac{2}{3} = 6.67k\Omega \quad (5)$$

$$R_s = 6.67k\Omega$$

The current required for the brightness of the LCD is given by;

$$I_{LCD} = V/R_s \quad (6)$$

$$= 5/6.67 = 0.7496A$$

$$I_{LCD} = 750mA$$

This is the current required to set the brightness or contrast of the LCD to display information without getting overheated or damage.

2.2.4 Relay driver section

The relay driver section consists of a BC547 transistor and a 5V relay for controlling the motors. The relay is an electromagnetic switch that is controlled by small current, and used to switch on or off relatively much larger current [13]. By applying a small current we can switch ON the relay, which allows a much larger current to flow. A relay is a good example of controlling AC devices using a small DC current. Commonly used relay is the Single Pole Double Throw (SPDT) relay, which will be used in the circuit. It has five terminals as shown in Fig. 7.

Table 1. Pin Connections and functions of 16x2 LCD module in the design

Pin	Name	Pin function	Pin connection
1.	V _{SS}	Ground reference	Connected to GND
2.	V _{DD}	Positive power supply for LCD	Connected to +5v
3.	V _E	Brightness adjust (contrast)	Connected to +5v via variable resistor
4.	R _S	Select register and instructions	Connected to port RB4
5.	RW	Select read or write	Connected to GND
6.	EN	Start data read or write	Connected to port RB5
7.	DO	Unused Data pins	Connected to GND
8.	D1	-	-
9.	D2	-	-
10.	D3	-	-
11.	D4	Data bus	Connected to RB0
12.	D5	Data bus	Connected to RB1
13.	D6	Data bus	Connected to RB2
14.	D7	Data bus	Connected to RB3
15.	A	Backlight anode	Connected to +5v
16.	K	Backlight cathode	Connected to GND

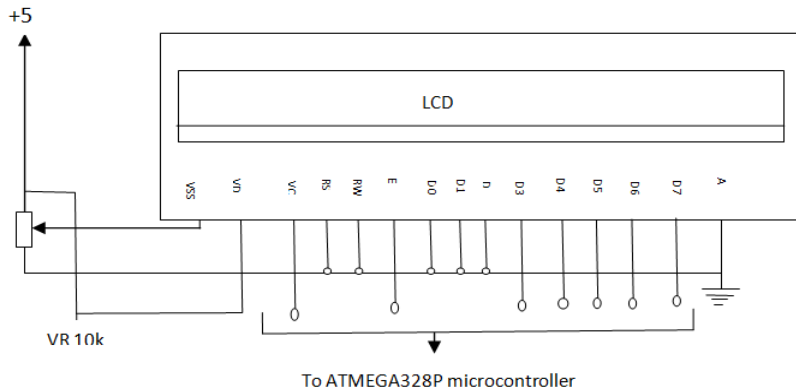

Fig. 6. The LCD display unit

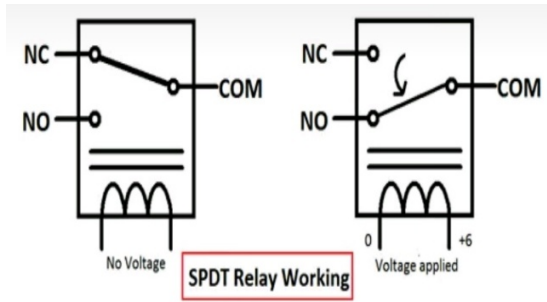

Fig. 7. SPDT relay working

When there is no voltage applied to the coil, COM (common) terminal is connected to the NC (normally closed contact). When there is some voltage applied to the coil, the electromagnetic field produced attracts the armature and the COM and NO (normally open contact) gets connected, which allows a larger current to flow. Relays are available in many ratings. A 5V operating voltage relay was used, which allows 392mA–5VDC to flow.

The relay is configured using a small driver circuit, which consists of a transistor, diode and resistor as shown in Fig. 8. The transistor is used to amplify the current so that full current (from the DC source) can flow through the coil to fully energise it. The resistor is used to provide bias to the transistor, and the diode is used to prevent reverse current flow when the transistor is switched off. Every inductor coil produces equal and opposite EMF when switched off suddenly. This may cause permanent damage to components, so the diode must be used to prevent such reverse current. To turn on the relay, we need to make the Arduino pin High where the relay module is connected.

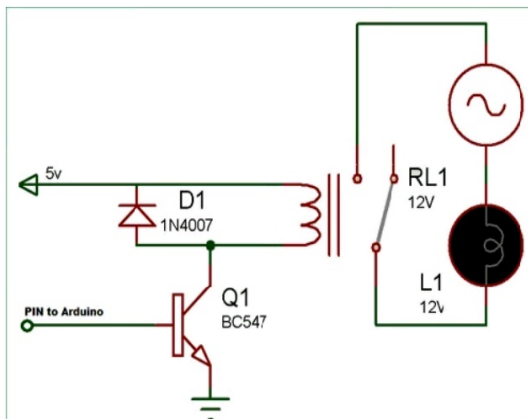

Fig. 8. Relay section circuit

2.2.5 5V DC Motor

The 5V dc motor is responsible for rotating the sliding door open and close with the help of relay switches. It is connected to a shaft mounted on the door. A commutated DC motor has a set of rotating windings wound on an armature mounted on a rotating shaft. The shaft also carries the commutator, a long-lasting rotary electrical switch that periodically reverses the flow of current in the rotor windings as the shaft rotates [14]. Thus, every brushed DC motor has AC flowing through its rotating windings. Current flows through one or more pairs of brushes that bear on the commutator; the brushes connect an external source of electric power to the rotating armature. The rotating armature consists of one or more coils of wire wound around a laminated, magnetically "soft" ferromagnetic core. Current from the brushes flows through the commutator and one winding of the armature, making it a temporary magnet (an electromagnet). The magnetic field produced by the armature interacts with a stationary magnetic field produced by either PMs or another winding (a field coil), as part of the motor frame. The force between the two magnetic fields tends to rotate the motor shaft. The commutator switches power to the coils as the rotor turns, keeping the magnetic poles of the rotor from ever fully aligning with the magnetic poles of the stator field, so that the rotor never stops (like a compass needle does), but rather keeps rotating as long as power is applied [16]. Fig. 9 shows a dc motor.



Fig. 9. A 5V DC motor

The circuit diagram depicted in the Fig. 10 shows the designed circuit diagram for motor operation. The single 5V dc motor is operated by two relays. One relay produces a negative voltage at a time for opening the door and the other produces a positive voltage at a time for closing the door.

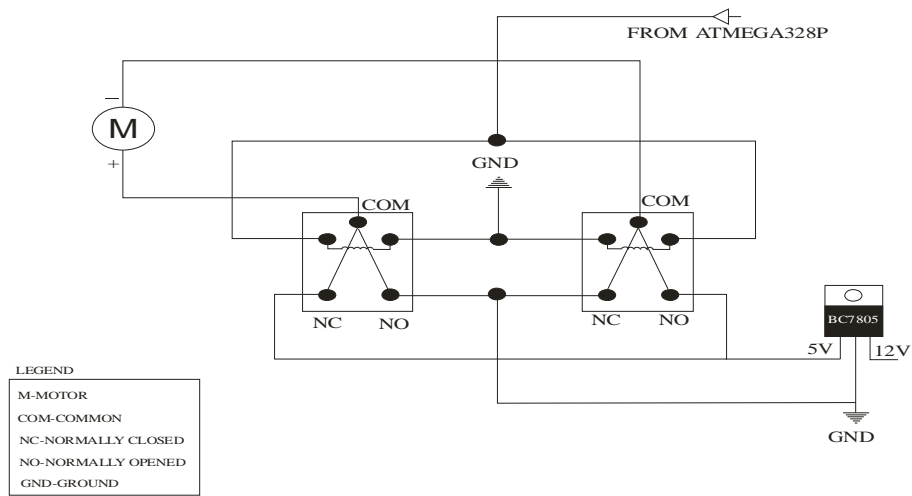

Fig. 10. Motor operation circuit diagram

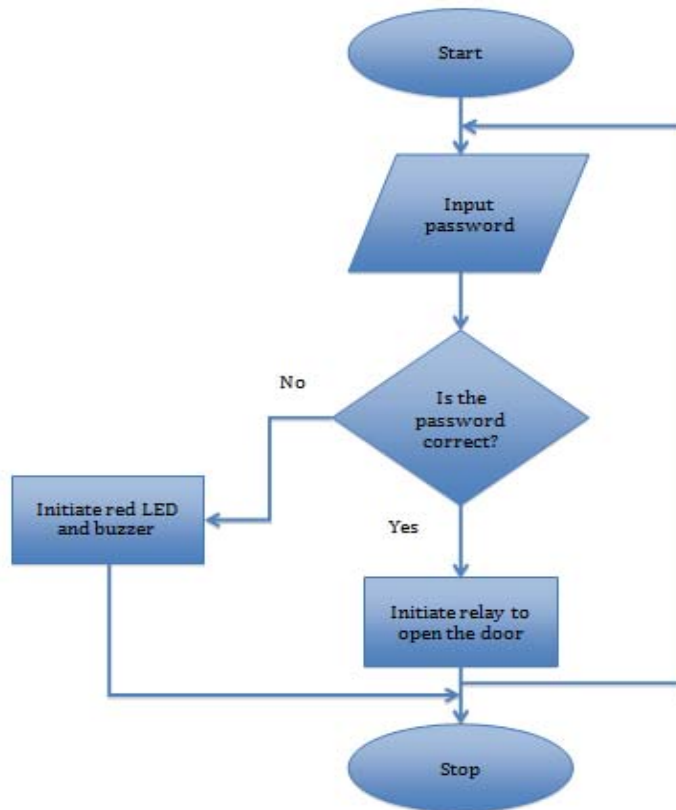

Fig. 11. Flowchart for the lock operation

2.2.6 Software development process

A software computer program called “Source code” controls the construction of the microcontroller based Electronic digital lock with

security notification. In computing, source code is any collection of computer instructions or commands written in some human-readable computer language, usually as text, to control hardware. The source code cannot be executed

directly by the microcontroller or any other computer machines unless it is compiled into a low level machine language called the "Object code" or "Hex file". The compiler used for compiling the source code used for this project work is the Arduino-Uno compiler.

However, the source code is written in accordance with the flowchart, which is given in Fig. 11. The flow chart illustrates how the compiled written program runs in the Atmega328 microcontroller. After the software program was written, it was compiled and checked for errors. Then the Arduino-Uno programmer kit was used to transfer the source code onto the Atmega328 microcontroller, before putting it onto the construction circuit board.

The other flowchart for changing the password is shown in Fig. 12 and this is how it works: whenever a user notice a password is being

used for quite a long period and might have been compromised, the user can modify the password of the lock without having to go back to reprogramming the microprocessor. This is because a provision was made for changing the password at the time of the code design. The user needs to press the hash (#) key for an option to insert the new password, and then the password is stored in the microprocessor for future use. A four key password was used in the system with restriction of numeric characters only.

The circuit diagram of the lock shows the connections between the different components of the project. Here, the whole Arduino microcontroller was used to represent the microprocessor. In this circuit diagram, the output is indicated by a buzzer. The modified and designed circuit diagram for the relay operation is also shown in Fig. 13.

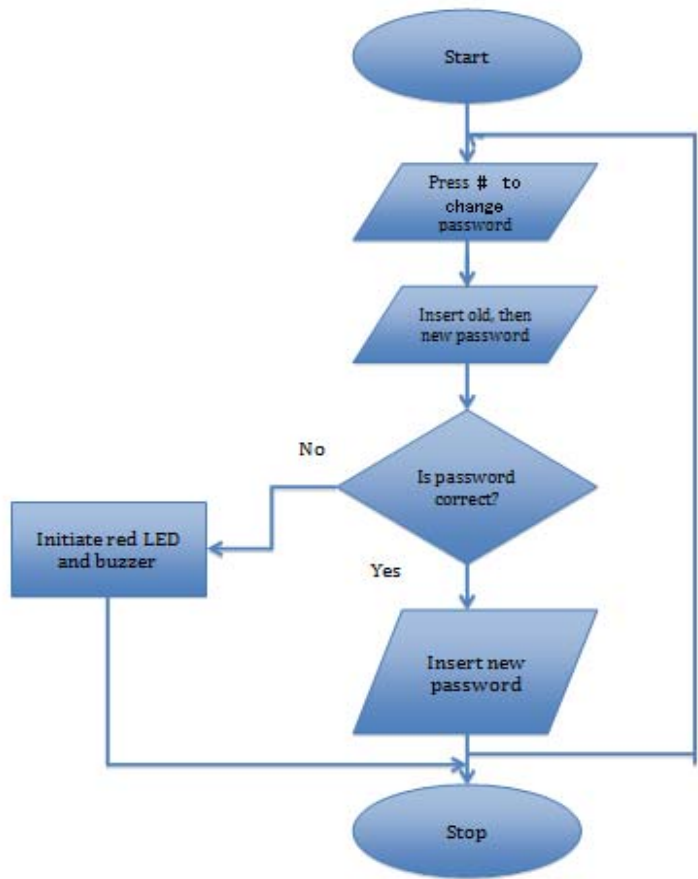

Fig. 12. Flowchart for changing the password of the lock

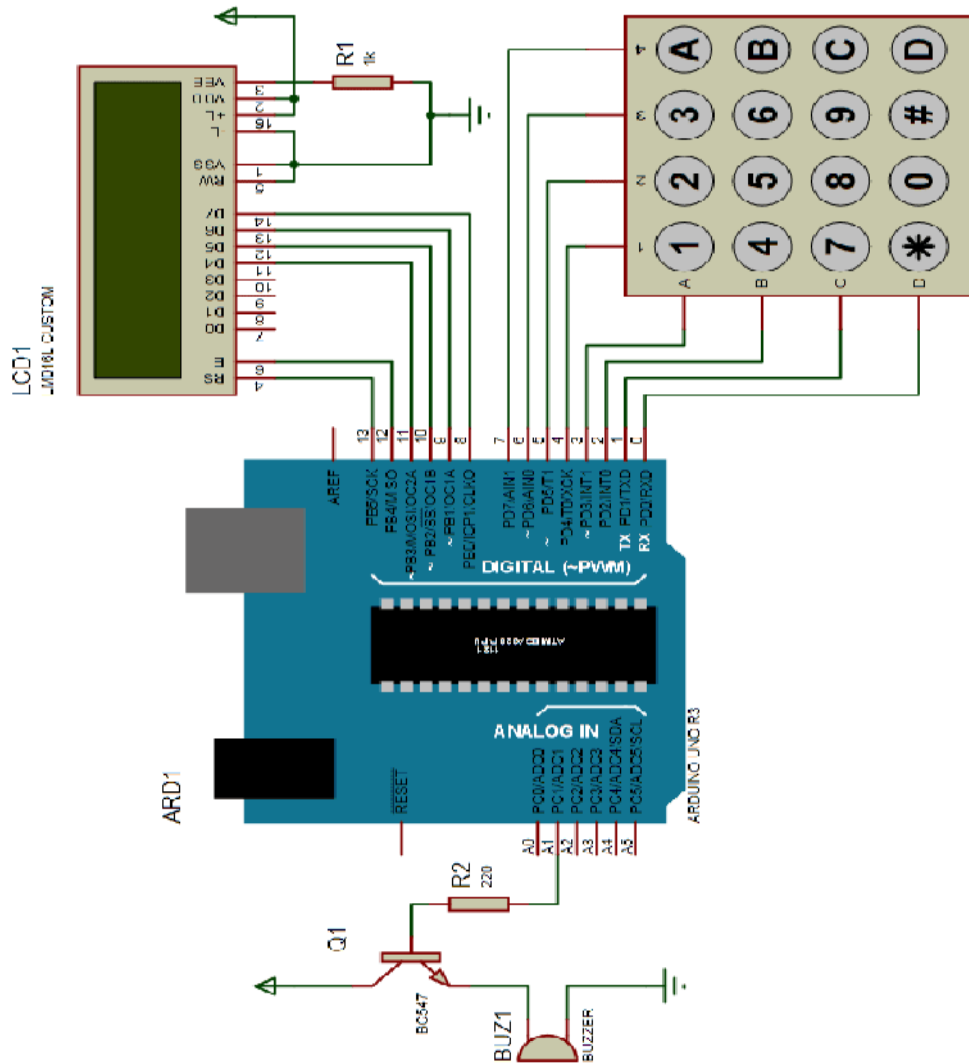

Fig. 13. Complete circuit diagram of the digital lock

3. RESULTS AND DISCUSSION

It is critical to know that the materials and components used works as expected. This is known after testing of each component used. The power supply unit was tested to ascertain its 12V dc supply. This was done using a digital multi-meter, and the supply was in the range of 11.98-12.12, with an allowable tolerance of $\pm 2v$. The Atmega328 microprocessor is a programmable IC, which needs to be programmed to suit the design. The source code was first compiled using an Arduino-Uno compiler. Proper concentration was given to the code during compilation in order to avoid any

logic errors. The hex file was then generated and transferred to the chip with aid of the Arduino-Uno Microcontroller board. The correlation between the designed value, standard value and measured value of the Microcontroller (Atmega328p) is shown in Fig. 14. All measurements are in volts, the chart shows that there is a slight difference between the designed value and the measured value. The design was simulated on a computer to study and analyze the behaviour of each stage before the physical implementation was carried out. Interactive electronic simulation software called Proteus VSM (virtual system modelling) was used to simulate the design.

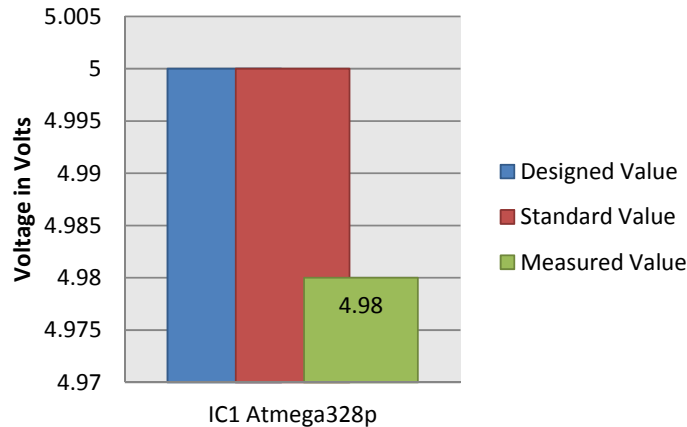

Fig. 14. Correlation between designed value, standard value and measured value of atmega328

Table 2. Components used and values

Components used	Design value	Standard value	Measured value
Capacitor C_1	554 μ f	1000 μ f	998.2 μ f
Resistor R_1	1k Ω	1k Ω	0.97k Ω
Resistor R_2	220 Ω	220 Ω	218 Ω
DC motor M_1	23.98k Ω	27k Ω	26.87k Ω
Crystal oscillator X_1	8MHz	8MHz	8.2MHz
IC ₁ Atmega328p	+5V	+5V	+4.98V
IC ₂ BC7805	+5V	+5V	+4.87V

The load unit is the motor, which is the output of the whole project. The motor opens and closes the door. A correct password was entered in accordance with the flowchart shown in Fig. 10. The lock opens by rotating the motor in the right direction. This indicates the correct operation of the lock. Another test was carried out on the lock to ascertain its security integrity, a wrong password was entered and the motor did not respond, the buzzer made a sound for four seconds to indicate an intrusion in the lock.

The alarm unit was also tested to confirm its operation. The alarm is not only used to indicate an intrusion in the lock, but it also indicates by a beeping sound when a user is accessing the lock. Each key strike on the keypad unit makes a beeping sound on the buzzer; this keeps the security personnel at the security post to be on alert and ready for interception when a buzzing sound goes on. The buzzing sound goes on only when a four wrong combination is entered. The switching unit is the two relay switches for opening and closing of the door. Upon powering the circuit, the closing relay is in normally closed position (NC), this means the motor is in constant anti clock-wise movement, when the right key is

entered, the relay changes the polarity of the motor, thereby rotating it in clockwise direction and the door opens. This is in accordance with the design of the lock and satisfies the design.

The keypad unit was tested also, every key was pressed and the keys worked correctly, each key pressed corresponds to the key number on the LCD screen. The LCD screen displays the key pressed on the keypad unit. The display unit (LCD) screen was tested too, and the display was impeccable. The keypad unit was also used to test the LCD screen, each key was pressed to see the corresponding value on the screen and there were correspondence and harmony between the keypad unit, the microprocessor and the LCD screen.

4. CONCLUSION

Electronic digital lock is totally based on Arduino. Arduino has been the brain of thousands of electronic design. The design of the microcontroller based electronic digital lock with security notification uses a four-digit pass key for its operation. The operation involves opening the door, closing the door, alarm upon wrong

password entry and changing of password. The design aims at creating an electronic security system capable of detecting an intruder and reporting to security personnel at a security post. The four (4) key combination password for the door entry work. The sliding door for opening and closing the door, the security notification feature was successful, and the circuit accommodates changing of password in case of a security breach.

The system differs from the conventional lock system which eliminates the use of an ordinary key. As compared to other microcontroller based digital lock it is easy and it required less hardware. The password can be and reset without using the external device and can be easily implemented. The whole digital lock system provides a secured architecture and without knowing the correct password sequence, it is impossible to open it. In every wrong password entry, the system goes in a locked state and an alarm occurs. However, if the total power loss of the system occurs, then it will go in the locked state and in that time nobody can open it. The evaluation shows that the design works well, consumes minimal power from the hardware and can unlock a door.

Future Scope:

- The electronic digital lock system may incorporate a circuit that is capable of alerting the lock owner of an intrusion through the Internet or Short Message (SMS).
- Also, since the door can only be operated with a numeric code, an auxiliary opening system should be incorporated to increase the security system.
- The security notification is only capable of working with one password for one user at a time, there may be a need for different users to access the system. A Fingerprint sensor can be added to the system so that entry will be allowed for the authorised person using their Fingerprints.

COMPETING INTERESTS

Authors have declared that no competing interests exist. The products used for this research are commonly and predominantly use products in our area of research and country. There is absolutely no conflict of interest between the authors and producers of the products because we do not intend to use these

products as an avenue for any litigation but for the advancement of knowledge. Also, the research was not funded by the producing company rather it was funded by personal efforts of the authors.

REFERENCES

1. Okih B.M, "Security Systems Technology and Applications", Kapapa Publishers Inc Gambia, 2012.
2. Milan, Verle, "PIC Microcontrollers", mikroElektronika; 1st edition, 2008.
3. S. Kumar, "Ubiquitous Smart Home System Using Android Application", International Journal of Computer Networks and Communications (IJCNC). 6: 33-43, 2014.
4. Shaba Firdosh et al, "Password Based Door Locking System Using Microcontroller" International Journal of Scientific Research in Computer Science, Engineering and Information Technology, IJSRCSEIT | Volume 2 | Issue 3 | ISSN: 2456-3307, 2017.
5. Annie P. Oommen et al, "Design and Implementation of a Digital CodeLock" International Journal of Advanced Research in Electrical, Electronics and Instrumentation Engineering (An ISO 3297: 2007 Certified Organization) Vol. 3, Issue 2, February 2014
6. Arnab Pramanik, "Digital Design of a Digital Combination Lock" International Journal of Engineering Research and Applied Science (IJERAS) ISSN: 2349-4522 Vol. 1, Issue 1, 2014.
7. Wei Liu and Yanping Wang, "AT89C52 Microcontroller-based electronic locks design" Applied Mechanics and Materials, ISSN: 1662-7482, Vol. 685, pp 378-383, Trans Tech Publications, 2014.
8. David, K. "The Making of Arduino". IEEE Spectrum, 2011-10-26.
9. AT89C51 microcontroller programming flash programmer circuit for AT89c55 Compatible with MCS-51TM Products Bytes In-System Reprogrammable Flash Memory Endurance [Online]. Available: <http://www.datasheetarchive.com/atmel%2089c55-datasheet.html>
10. Datasheet, 89C55 - 8-Bit Microcontroller with 20K Bytes Flash -ATMEL Corporation [Online]. Available: <http://www.alldatasheet.com/datasheetpdf/pdf/56234/ATMEL/89C55.html>

11. J. Ilett, "How to Use Intelligent LCD'S, " Everyday Practical Electronics, February 1997.
12. Basil Hamed "Efficient Authorized Access Security System Control Using ATMEL 89C55 & Mobile Bluetooth" International Journal of Computer Theory and Engineering, Vol. 4, No. 1, February 2012
13. Theraja B. L, Theraja A. K. " A Text book of Electrical Technology" S. Ch and Company Ltd, University press, PP 411-424. 1997.
14. John Bird, "Electrical and Electronic Principles and Technology" Third edition, Published by Elsevier Ltd. All rights reserved. 1997.
15. Datasheet Arduino Available: <http://arduino.cc/en/Guide/HomePage>
16. Kim, S. "Electric Motor Control: DC, AC, and BLDC Motors" Elsevier. ISBN: 9780128123195, 2017-05-09.