

OPTIMAL DESIGN OF INDEPENDENT MINI HYDRO-PHOTOVOLTAIC-BATTERY-DIESEL HYBRID POWER SYSTEM FOR ERIN-IJESHA WATER FALL, NIGERIA

ABSTRACT

In order to provide a sustainable energy system, especially in rural areas where grid electricity is not economically or geographically feasible, renewable energy sources appear to be one of the most effective solutions. However, the fluctuating nature and the high cost of kWhr units produced make the system unreliable and not easily affordable to the rural dwellers. This paper discussed the feasibility of renewable energy hybrid system and proposed a reliable independent Hybrid Power System (HPS) for rural application in Nigeria. Erin-Ijesha-a typical rural village in Osun State, Nigeria was used as a case study. Solar irradiation, the hydro potential of the waterfall and load patterns were collected and analyzed for the study area. The electrical load for the village was estimated through the use of questionnaires. HOMER energy modeling software was used to develop the simulation models. The optimized results showed that mini-hydro-photovoltaic-battery combination with Cost of Energy, COE of \$0.218/kWh is better than any other combinations considered in the work. It was revealed that purchasing electricity from the grid is better than any other hybrid combinations in terms of COE at \$0.121/kWh. Nevertheless, from the result obtained, the HPS is considered cost-efficient and reliable in such rural areas especially where grid extension is geographically or economically infeasible.

Keywords: Sustainable energy, off-grid, waterfalls, hybrid, mini-hydro and photovoltaic system.

1. INTRODUCTION

Off-grid rural dwellers deserve efficient, reliable and cost-effective renewable energy as an alternative to the costly and environmentally unfriendly power supplied by the conventional energy system. Considering the rising price of conventional energy source and its global warming consequences such as worldwide floods, draughts and rising sea levels, renewable energy is now a viable supply option to provide reliable and affordable energy services [1, 2]. However, a system which depends entirely on one renewable energy source cannot be a reliable source of electricity, due to its stochastic nature, especially for off-grid rural dwellers. Moreover, the high capital cost, cost of generation and maintenance makes the cost of unit of kWhr produced too high, and consequently a financial challenge to the rural dwellers. On the other hand, there is usually abundance biomass, solar irradiance and high wind speeds in some of these areas, which can be harnessed to form a hybrid system to complement the energy shortage, so as to ensure reliable and continuous supply [2, 3].

A hybrid power system is defined as a combination of different, but complementary energy generation systems based on renewable

energy or conventional energy sources. It captures the best features of each energy source [4]. The hybrid energy system is pollution free, has short gestation period and is environmental friendly. It improves load factors of generators and ensures better exploitation of renewable energy leading to saving on maintenance and replacement cost.

Several authors have worked in this area and successful results have previously been obtained with hybrid systems in developing countries. Celik in 2002 [5] conducted a techno-economic analysis of an independent PV/Wind hybrid power system. He concluded that an optimum PV/Wind hybrid combination provides higher performance than other of the single system for the same cost of battery storage capacity. Tamirat [6] made a feasibility comparison of independent electrification at Dillamo and Gode sites in Ethiopia by either of the wind, solar PV and micro hydropower system. The possibility of combining the resources into hybrid system was not considered and the analysis was done manually without any computer tool. Diaf in 2008 [7] investigated the design and used micro hydroelectric techno-economical optimization of PV/other system under various meteorological conditions. HOMER software was used to simulate

PV/Micro hydroelectric hybrid system in the North of Africa by Bekele and Palm [8]. The total annual cost for each configuration was then calculated and the combination with the lowest cost is selected to represent the optimal mixture. The method is costly because of its unsuitable combination.

Rohit [9] performed in his studies simulations with HOMER on an off-grid electricity generation with renewable energy technologies and compared an optimized hybrid system to an expensive grid extension. It was concluded that decentralized renewable energy technology off-grid is the best alternative to grid extension and can be cost effective even if the grid connection was possible. However, the system can't provide a viable solution if it only relies on one energy source. Ahmed in 2012 [10] presented a utility interactive hybrid WEC/PV/FC power system with Maximum Power Point Transfer (MPPT) and dc bus voltage regulation. It is worthwhile to design a hybrid system that is reliable and efficient. This can be achieved to have desired attributes at the lowest acceptable cost which can address limitations in terms of reliability, flexibility, efficiency and emissions [11]. The proposed hybrid system was able to provide almost continuous electric power with better reliability than a single source.

In this paper, the addition of mini-hydro electrical systems especially a waterfall which maintains average supply through the year is expected to increase the reliability of the hybrid system and thus reduces the Cost of Energy, COE, for the area under study. The hybrid renewable resource consists of a mini hydro turbine (waterfalls), solar photovoltaic (PV) and battery system (BATT). Diesel Generator (DG) is added as part of back-up.

2. ENERGY SITUATION IN NIGERIA

The generation capacity in Nigeria is grossly inadequate and unreliable to meet the demand of the teeming customers yearning for electrical power supply. Even those who are connected to the national grid experience perennial power outages. The current installed capacity of grid electricity is about 8,647 MW, of which about 67 percent is thermal and the balance is hydro-based. The average power generation fluctuates between 3,000 MW and 4,000 MW while the average demands for electricity are about 10,000

MW [12, 13]. It is estimated that 26,561 MW will be required in the next five years to meet demand as envisioned in the vision 20:2020 target [13].

Renewable energy resource is a resource that can be regenerated through natural process within a relatively short time [14]. Nigeria has renewable energy resources in excess of 1.5 times that of fossil energy resources in the country, in energy terms [14,15]. The low level of electricity access in Nigeria, and particularly in the rural areas, can be increased through the use of these renewable energy resources for sustainable development [13, 14, 15]. Some of the major challenges facing the development of renewable energy in the country are high capital cost, intermittency of reserve availability, inadequate fiscal and economic incentives, low level of public awareness, inadequate indigenous capacity in design and construction and lack of capacity for the local manufacturing of alternative energy system components resulting into limited supply at higher cost [14, 15]. Nigeria, like other developing countries in the world, is blessed with abundant renewable energy sources, which can be exploited in achieving a rapid and effective development of its rural areas.

3. RESEARCH METHODOLOGY

The technical feasibility analysis of Mini hydro-PV-BATT-DG for Erin-Ijesha water fall was carried out in this work. The methodology adopted in this work involved site identification, data acquisition, load demand estimation, renewable energy assessment of the study area and modeling of the HPS components using HOMER software. A questionnaire was prepared for the purpose of conducting a survey to determine the load demand. The year is divided into the raining season (April-October) and dry season (November-March) depending on the demand and energy consumption pattern. The estimated power demand data, solar resource, hydro resource, DG parameters and financial data (Appendix) were used as input into the HOMER software. These were suitably modeled using Hybrid Optimization Model for Electric Renewable (HOMER) software. The hybrid model is shown in Fig.1.

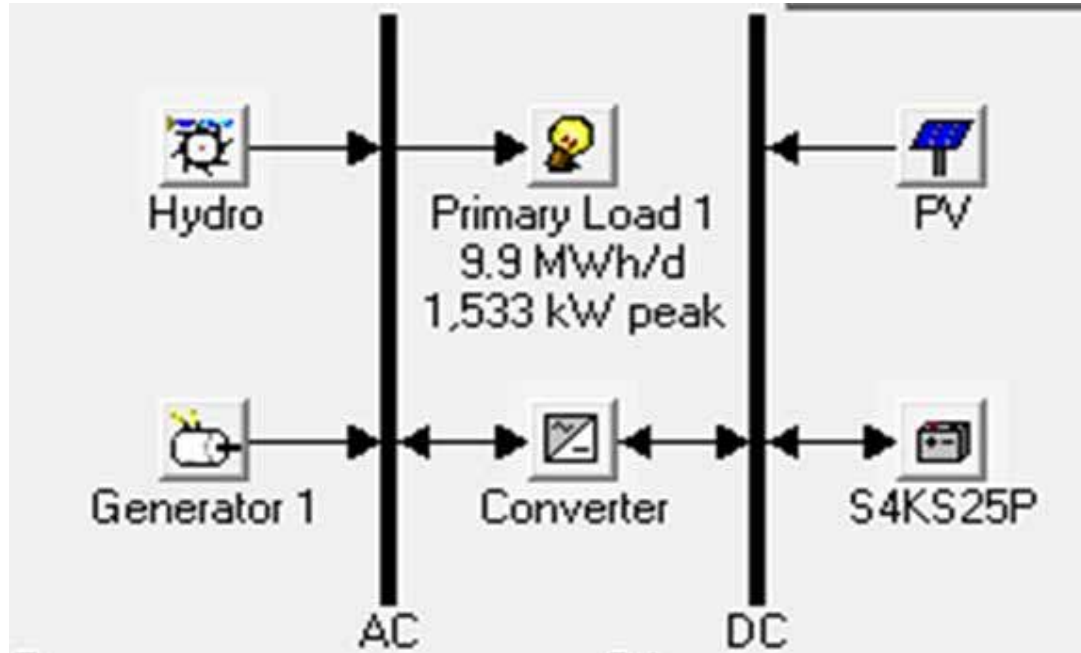

Fig. 1: Hybrid model of the Mini HYDRO-PV-BATTERY-DIESEL SYSTEM

3.1. Description of the Study Area

Erin Ijesha water fall, also known as Olurin water fall is used as a case study. The waterfall is located at latitude $7^{\circ}3'$ and $8^{\circ}45'$ North and longitude $4^{\circ}31'$ and $5^{\circ}30'$ East. Fig. 2 shows the geographical map of Erin-Ijesha. Erin-Ijesha water flows among rocks and splashes down with great force to the evergreen vegetation around. The first level of Erin Ijesha water fall is shown in figure 3. The area can serve as a mountainous exercise. The breeze at the water fall is cool and refreshing [16]. The atmospheric temperatures ranges from $30-34^{\circ}\text{C}$ while the annual rainfall average is 1500cm. The fall has seven levels to ascend. It is characterized by two major seasons, the rainy season and the dry season. The raining season normally occurs

between April and October, while the dry season is between November and March. The community has been depending on bush fires and kerosene lantern for lighting. Majority of the inhabitants are arable farmers, they plant yams, cassava and rice. Table 1 showed the average monthly climatic data of the study area. The detailed parameter of the HPS components is shown in the appendix.

3.2. Data Acquisition

The hydrological data for the past twenty years (1995-2015) for the study area were collected from Nigeria Metrological Centre, Oshogbo, Osun State [17]. Technical data for PV modules, hydro generator, inverters and battery bank were taken from the manufacturers specifications (datasheet).



Figure 2: Map showing the geographical location Erin-Ijesha water fall [17].



Figure 3: First level of Erin-Ijesha water fall

Table 1: Average Monthly Climatic Data

Month	Solar Irradiance (kW/m ²)	Temperature (°C)	Stream Flow (m ³ /s)
January	5.52	26.0	1.45
February	5.68	28.1	1.46
March	5.59	28.3	2.71
April	5.26	28.1	2.71
May	4.94	27.0	2.73
June	4.43	25.5	2.83
July	3.82	24.5	2.89

August	3.62	24.5	3.30
September	4.00	24.6	3.51
October	4.57	25.6	3.62
November	5.13	26.2	1.51
December	5.32	25.7	1.46

3.3. Assessment of the Electrical Power Demand of the Study Area

The number, time of usage and the size of the appliances in each household were determined through direct interview. A questionnaire was prepared and used in conducting a survey to determine the load demand. The energy needs of the area were classified as residential, agro-allied and small scale industries. The energy requirements in the village varied from season to season. Figure 4 showed the hourly load consumption for Erin-Ijesha. The scaled load is shown in Table 2. The peak load required is 1533kW while the average load is 9860kWh/day.

3.4. Estimating the renewable energy sources

The renewable energy potentials of the area were assessed and estimated as discussed in the subsequent sections.

3.4.1. Estimating the Hydropower Potentials of the Water fall.

This involves determination of technologically feasible limits of the gross hydropower potential (GHP) of the dam. The hydro potential of a site is given by equation 1 [3].

$$Q_{site} = k \left[\frac{A_{site}}{A_{gauge}} \right] Q_{gauge} \quad \dots\dots\dots 1$$

where A_{site} is catchment area of power plant (m^3), A_{gauge} is catchment area of gauge (m^2), Q_{site} is discharge at site (m^3/s), Q_{gauge} is discharge at gauge (m^3/s), and k is scaling constant or function [18]. The power available from the turbine was calculated using the power equations in 2 and 3[19, 20].

$$P(W) = \eta \rho g Q H_n \quad \dots\dots\dots 2$$

$$H_n = H_g - [\zeta_h (H_g) + h_w] \quad \dots\dots\dots 3$$

where P is power (Watts), η is the overall efficiency, ρ is the density of water (1000 kg/m^3), g is the acceleration due to gravity (9.8 m/s), Q is the water discharge expected to pass through the turbine (m^3/s), H_g is the gross Head (m), H_n is the net Head (m), ζ_h is the conduit head percentage loss (typically 3 %-8 %) and h_w is the maximum tail water level [3]. The hydro resource of the water fall is shown in Fig. 5.

3.4.2. Solar Irradiance Assessment

It is necessary to estimate the amount of sunshine, the site receives. The average solar radiation is $4.82 \text{ kWh/m}^2/\text{day}$. This is as shown in Figure 6.

4. MATHEMATICAL MODELS OF THE HYBRID POWER SYSTEM (HPS)

The different HPS components consisting of small hydro generator model, photovoltaic (PV) model and the battery model required for simulation are as described below.

4.1. Small hydro Generator

The electrical power output of the small hydropower unit is given as in equation 4 [21].

$$P_{SHP} = \eta_h \rho_{water} g H_{net} Q \quad \dots\dots\dots 4$$

where P_{SHP} is the power output of the turbine, η_h is the hydro efficiency, ρ_{water} is the density of water, g is the acceleration due to gravity, H_{net} is the effective head, Q is the flow rate.

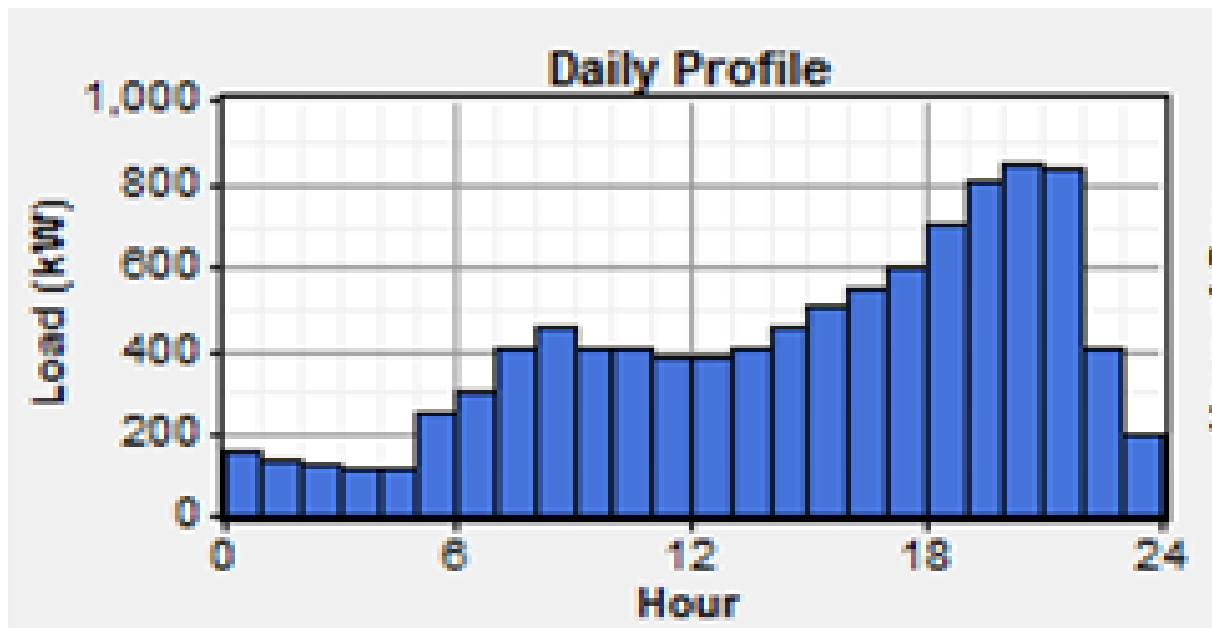

Fig. 4: Hourly load consumption for Erin-Ijesha water fall

Table 2: Scaled load.

	Baseline	Scaled
Average [kWh/d]	9,860	9,860
Peak [kW]	1,533	1,533
Average [kW]	411	411
Load Factor	0.268	0.268

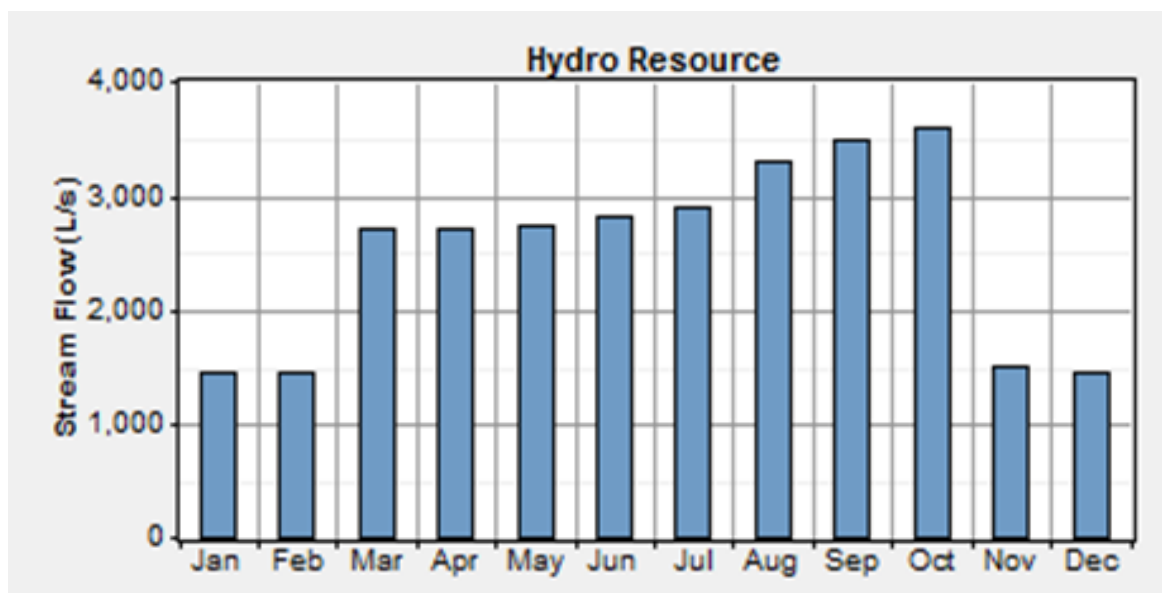

Fig. 5: Hydro resource of Erin-Ijesha water fall (2015)

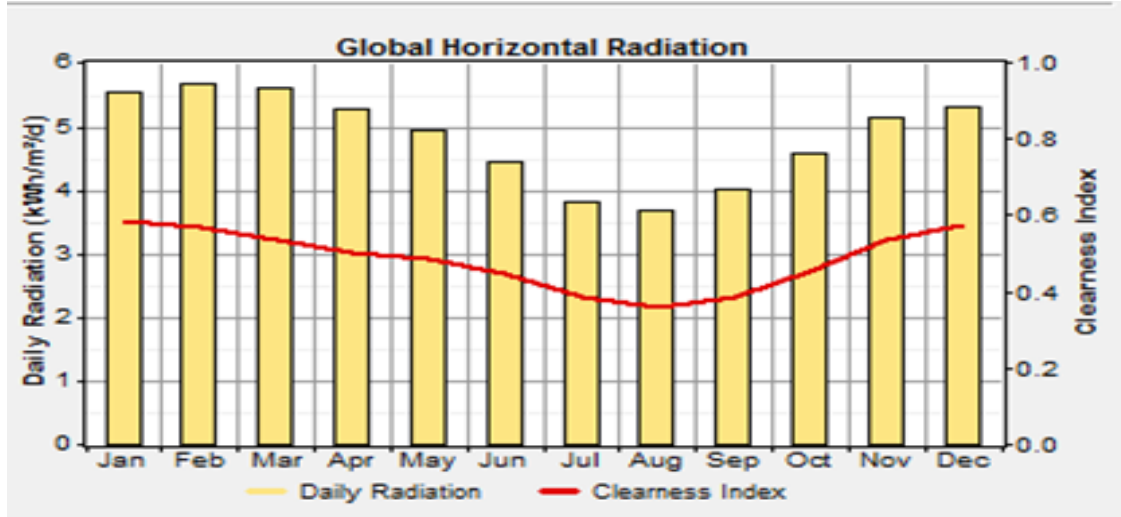

Fig. 6: Solar radiation of the area

4.2. Photovoltaic (PV) Model

The PV output power is affected by the variation of cell temperature and variation of incident solar radiation. The maximum power output from the PV cell can be calculated using following equation 5 [22]

$$P_{out-pv} = P_{r-pv} \left[\frac{G}{G_{ref}} \right] \left[1 + kT(T_c - T_{ref}) \right] \dots 5$$

where P_{out-pv} is the output power from the PV cell, P_{r-pv} is the rated power at reference conditions, G is the solar radiation (W/m^2), G_{ref} is the ($1000W/m^2$) solar radiation at reference conditions, T_c is the cell temperature, T_{ref} is the cell temperature at reference conditions ($25^\circ C$), kT is the temperature co-efficient of the maximum power ($kT = -3.7 \times 10^{-3}/1^\circ C$ for Mono and Poly crystalline, Si), $T_c = T_{amb} + 0.0256 \times G$ where, T_c and T_{amb} are the cell and anti-temperature respectively [22].

4.3. Battery Banks Model

Koutroulis *et al.* in 2006 [23] calculated the capacity of the battery at a point in time t , as follows in equation 6.

$$C(t) = C(t-1) - \eta_{batt} \left(\frac{P_B(t)}{V_{BUS}} \right) \Delta t$$

.....6
 $C(t-1)$ is the battery capacity at the previous increment of time, η_{batt} is the battery and trip efficiency, $P_B(t)$ is the power supplied or used by the battery, V_{BUS} is the voltage of the bus that the system is connected to, Δt is the increment at time used is as given in equation 7[23].

$$P_B(t) = E_g(t) - E_i(t) \dots 7$$

$E_g(t)$ Is the energy generated in that hour by hydraulic generator and the PV panels, $E_i(t)$ is the load that needs to be supplied. $P_B(t)$ Is therefore negative when the energy generated by the other energy sources is not sufficient to supply the system and the battery supplies additional power to the system. The value is positive when the battery is charging.

4.4. Diesel Generator (DG) Model

The diesel generator is an energy conversion system from fuel to electricity with a conversion efficiency of, so that it can be described by equation 8[24].

$$E_{DG} = \eta_{DG} E_{ff} \dots 8$$

E_{ff} is the total energy content of oil which is roughly proportional to the volume of oil.

4.5 Results Validation

HOMER model was validated by comparing the measured stream flow (L/S) and the measured solar radiation data (kWh/m³/d) with the simulated results obtained from HOMER software. The correlation coefficient is 0.91. This shows a good correlation between the two results. HOMER software was then used for the simulation.

5. RESULTS AND DISCUSSION

The appropriate input resource parameters were used as input into the software. The simulation results with different types of renewable energy technology combinations. The optimal combination of hydro-PV-Battery with COE of \$0.218/kWh is the most cost-effective. This is as shown in Table 3.

Table 3: Optimal results for the hybrid system

PV (kW)	Hydro (kW)	4KS25P	Converter (kW)	Initial capital	Operating cost (\$/yr)	Total NPC (\$)	COE (\$/kWh)	Renewable Fraction
4000	68.1	10000	2000	8507,619	118.562	10,023,242	0.218	1.00

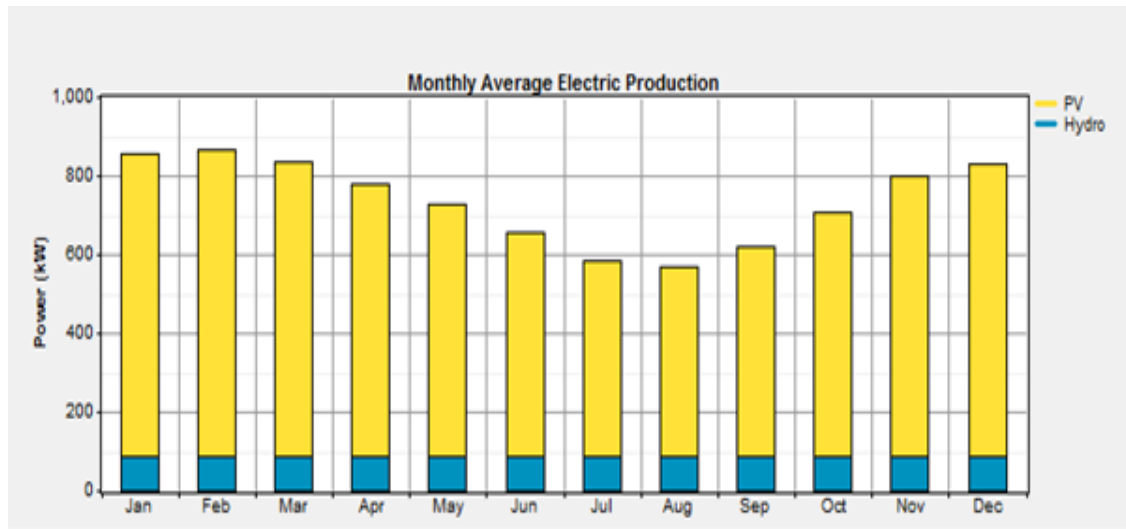

Fig. 7: Electricity production of the optimal hybrid system (without DG)

Table 4: Percentage contribution of each of the generators in the Hybrid System without DG.

Production	kWhr/yr	%	Production
PV Array	5,681,789	88	PV Array
Hydro Turbine	760,664	12	Hydro Turbine

Table 5: Simulation results for the hybrid system with DG

PV (kW)	Hydro (kW)	Generator	4KS25P	Converter (kW)	Initial capital	Operating cost (\$/yr)	Total NPC (\$)	COE (\$/kWh)	Renewable Fraction
4000	68.1	1200	5000	2000	8,452,128	124,665	10,085,766	0.221	0.988

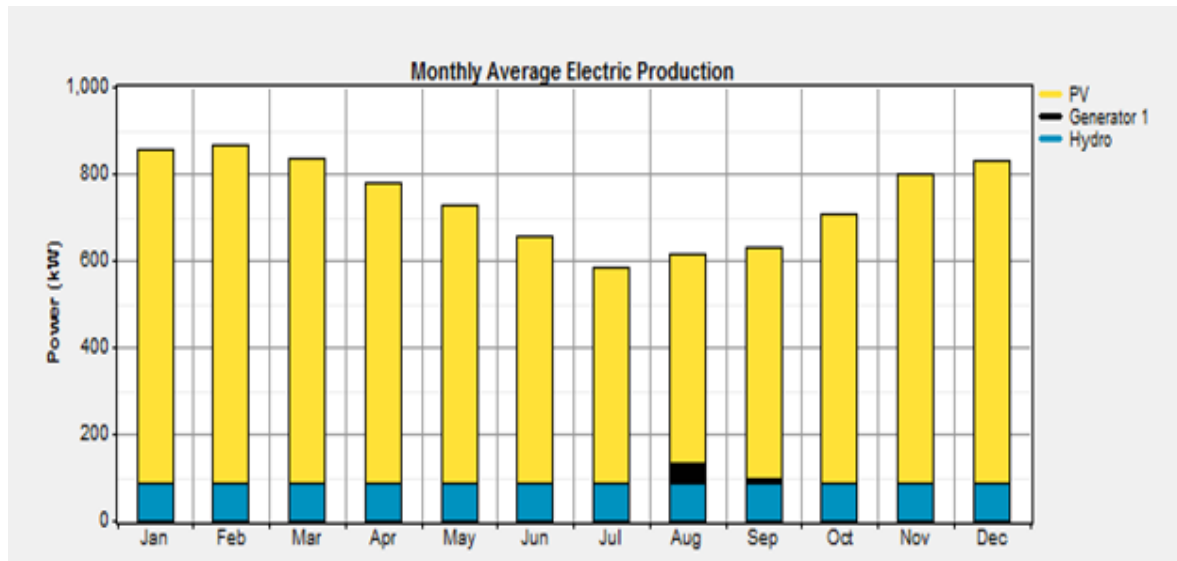

Fig. 8: Electricity production of the optimal hybrid system (with DG)

Table 6: Percentage contribution of each of the generators in the Hybrid System with DG.

Production	kWhr/yr	%
PV Array	5,681,789	88
Hydro Turbine	760,664	12
Diesel Generator	43,542	1
Total	6,485,995	100

The electricity production for optimal hybrid system is as shown in Fig. 7 with the percentage contribution of each of the HPS components shown in Table 4.

However, when the hybrid system is connected with the DG for reliability the COE is \$0.221/kWh. This is as shown in Table 5. The electricity production is as shown in Fig. 8 and the percentage contribution is as shown in Table 6.

6. CONCLUSION AND RECOMMENDATIONS

The feasibility of mini hydro-PV-DG-Battery hybrid system for Erin-Ijesha waterfalls, Nigeria has been done in this work. The result obtained showed that mini hydro-PV-DG-Battery hybrid combination is better than any other combinations. In case, there is the presence of hydro resource, the hydro-based renewable energy hybrid system offers the best in terms of cost and

reliability. The study revealed that purchasing electricity from the grid is better than any other hybrid power system combinations in terms of COE. HPS is cost-effective and reliable in rural areas where grid extension is geographically infeasible.

In view of some of the advantages of the hybrid technology, there is a need for transformation from single source renewable energy technologies to hydro-based HPS in order to improve the standard of living of the rural dwellers.

REFERENCES

- Razak JA, Sopian K, Nopiah ZM, Zaharim A, Yusuf A. Optimal operational strategy for hybrid renewable energy system using genetic algorithm. 12th WSEAS Int. Conf. on Applied Mathematics, Cairo, Egypt. 2007. 235-242.
- Fagbohun OO, Adebajani BA. Integrated renewable energy sources for decentralized systems in developing countries. Journal of Electrical and Electronic Engineering(JEEE), India. 2014; 9(5) ver.1:26-35. Aned-

ddl:12.1676/iosr-jeec-E09512635;doi:10.9790/1676-09512635.

3. Adepoju GA, Adebajni B. Feasibility study and optimal design of small hydropower-photovoltaic diesel generator hybrid power system for Itapaji-Ekiti, Nigeria. *Journal of Scientific Research and Reports*. 2016;11(2):1-10.
4. Duflo-Lopez R, Bernal- Agustn JE. Design and control strategies of pv-diesel systems using genetic algorithm. *SolarEnergy*. 2005;79(1):33-46.
5. Celik AN. Optimization and techno-economic analysis of autonomous photovoltaic-wind hybrid energy system in comparison to single photovoltaic and wind systems. *Energy Conversion and Management*. 2002; 43(18): 2453-2468.
6. Tamrat B. Comparative Analysis of Feasibility of Solar PV, Wind and Micro Hydropower Generation for Rural Electrification in the selected sites of Ethiopia, M.Sc. Thesis, Addis Ababa University, Ethiopia. 2007.
7. Diaf. Design and Techno-economical optimization for Hybrid PV/Wind System under various meteorological conditions. *Applied Energy* 85. 2008; (10): 968-987.
8. Bekele G, Palm B. Wind Energy Potential Assessment at Four Typical Locations in Ethiopia. *Applied Energy*. 2009; 86(3):388-396.
9. Rohit S. Off-grid Electricity Generation with Renewable Energy Technologies in India; An application of HOMER. University of Dundee, India. 2011; 12-30.
10. Ahmed NA. On-Grid Wind/Photovoltaic/Fuel Cell Energy System. *IEEE publications on IPEC*. 2012; 104-109. doi: 978-1-4673-4584-2/12
11. Matin MA, Deb A, Nasir A. Optimum Planning of Hybrid Energy system using HOMER for Rural Electrification, *International Journal of Computer Applications (0975-8887)*. 2013; 66(13): 45-53.
12. Cred C. Energy Efficiency Survey in Nigeria: A Guide for Development Policy and Legislation. 2014; 3: 120-125. Retrieved from www.arpapress.com.
13. Presidential Task Force on Power. Electric Power Investors forum by Bureau of Public Enterprises (BPE). *Power Generation (Status and outlook)*. 2014; 15-16.
14. ECN (2014). Draft National Renewable Energy and Energy Efficiency Policy (NREEEP) Energy

Commission of Nigeria.

15. Sambo AS. Renewable Energy for Rural development; The Nigerian Perspective. *ISESCO Science and Technology Vision*. 2005; (1): 12-22.
16. Akinola OO, Adeyemi EO, Abimbola FO. Socio Economic Impacts of Erin-Ijesha Water fall, Erin-Ijesha, Osun State, Nigeria. *Journal of Economics and Sustainable Development* . 2013; 4(2): 113-121.
17. Adegboyega GA. Micro-Hydroelectric Power generation from waterfalls: A case of study of Erin Ijeshawater falls, Osun state, Nigeria. *International Journal of Science, Engineering and Technological Research (IJSETR)*. 2015; 4(6): 2075-2080.
18. Bhandari B, Poudel SR, Lee KT, Ahn SH. Mathematical Modeling of Hybrid Renewable Energy System: A review on Small hydro Solar-Wind Power Generation. *International Journal of Precision Engineering and Manufacturing Green Technology*. 2014; 1(2): 157-173.
19. Otun JA, Onemano JI, Alayande AW. Assessment of the Hydropower Potential of Kangimi Reservoir in Kaduna State of Nigeria. *Nigerian Journal of Technology (NIJOTECH)*. 2012; 3(3):300-307.
20. Shobayo DI, Adejumobi IA, Akinwale AT. Assessment of the Small Hydro Potential of the Opeki River, Southwestern Nigeria. *Science Journal of Engineering*. 2014; 2(3): 25-31.
21. Ashok S. Optimized model for community based Hybrid Energy System. *Renewable Energy*. 2007; 32(7): 1155-1164.
22. Daudid AK, Isirial M, Kukhun B, Mahmood MM. Simulation of a Hybrid Power System consisting of Wind Turbine, PV, Storage Battery and Diesel Generator; Design, Optimization and Economical Evaluation. *International Journal of Energy Engineering*, 2011: 56-61.
23. Koutroulis E, Kolokotsa DJ, Potirakis A, Kalaitzakis K. Methodology for optimal sizing of stand-alone PV/Wind Generator Systems using Genetics Algorithm. *Solar Energy*. 2006; 80(9): 1072-1099.
24. Vahabzadeh A, Separi F, Samkush M, Jafari M. Optimal Sizing of Hybrid Energy resources for Electricity Distant Rural areas of Iran. *CIRD Workshop-Lisbon*. 2012: 29-30.

Appendix

Detailed Parameters of the Components

Details of Small hydro power Turbine		PV Specification		Battery Specification	
Nominal Power (kW)	68.1kW	Rated power	200W	Minimum life time	4years
Life time	25years	Capital cost	\$3500/kW	Initial state of charge	100%
Available Head	75.88m	Replacement cost	\$3500/kW	DOD	80%
Design flow rate	122L/s	Operation and Maintenance cost	\$5	Efficiency	80%
Turbine efficiency	75%	Life time	25yrs	Capital cost	\$1710/kAh
Capital cost	\$430,247			Replacement cost	\$1710/kAh
Replacement cost	\$234,000			Operation and Maintenance cost	\$76/kAh
Operation and Maintenance cost	\$10,308				
Details of DG model				Converter details	
Size	400kW	Capital cost	\$503.08/kW	Size	1000kW

Quantity	1	Operation and Maintenance cost	\$15/hr	Capital cost	\$8043
Life time	20,000	Replacement cost	\$503.08/kW	Replacement cost	\$8043
Price	\$0.884/litre			Operation and Maintenance cost	\$0