

Original Research Article

Dynamic DC motor-gear-alternator (MGA) system

Abstract

Recent research has indicated that the permanent magnet motor drives can be modeled by ignoring the inductance because it has small value compared to resistance. In this paper, we derived the defining equations for the MGA without ignoring the inductance, developed transfer function and design a Simulink model for the system. The complete model is then tested using some numerical values. The transfer function provides a basis for determining important system response characteristics without solving the complete differential equation. Using the assumed data, the output voltage changes exponentially with time. This indicates that the model is describe the dynamics of the MGA system

Aims

- (i) To construct a mathematical model describing the dynamics of the MGA set coupled through a gear ratio
- (ii) To design transfer function, which is a compact description of the input/output relation for the model.
- (iii) To construct a Simulink model of MGA System.
- (iv) Test the model using numerical values(assumed data)

Place and Duration of Study

Moi University, Department of Mathematics and Physics, between May 2015 and July 2016.

Keywords: *DC motor, alternator, gears, transfer function, Simulink.*

1 Introduction.

A DC Motor-Gear-Alternator (MGA) system is a device for converting electrical power to another form. Typically, MGA sets are used to convert frequency, voltage, or phase of power. Large motor-generators are widely used to convert industrial amounts of power while smaller motor-generators are used to convert battery power to higher voltages. A need exists for a low cost, high power electrical alternator capable of operating at low energy. Such alternators may be directly wind-driven by large propellers or may also be directly driven by water wheels or turbines in streams or dams or the one driven by DC motor. Some of these require high efficiency conversion of motive power to electrical power. Such systems, when operated as vehicle propeller, can eliminate the need for internal combustion engine. Shaik Rasheed Ahameed designed a simple recycling AC electrical energy generation system with small DC input & high efficiency with good load handling capability. The main intention of his research work is to design low cost AC electrical energy generation implementation system without any mechanical energy input [1]. The present study intends to construct a Mathematical model for a Motor-Gear- Alternator set which is used to describe

the dynamics of the system. MGA is very often used in industrial applications, for instance, motors have application in servo systems used in robotics and other motion control devices [2], in many engineering fields such as model analysis, control system design, and condition monitoring [3]. The mathematical model can be used to explain the behavior of such system and to predict its response to various inputs at different conditions [4].

Methodology

The Laplace transform method is a very useful mathematical tool [5, 6] for solving linear differential equations. By use of Laplace transforms, operations like differentiation and integration can be replaced by algebraic operations such that, a linear differential equation can be transformed into an algebraic equation in a complex variable s . The solution of the differential equation may be found by inverse Laplace transform operation simply by solving the algebraic equation involving the complex variable s .

System Modeling

Since some mathematical problems are to be solved, a mathematical model of the dynamics of the control system components and subsystems are to be formulated. The differential equation and the state variable representation are very popular mathematical models for describing the dynamics of a control system. The transfer function model is applicable if the system is linear. If the description of the system behavior is linguistic then fuzzy logic and fuzzy model of the system will be needed [7-9].

Simulation diagram from transfer function

We presented here one method for deriving a simulation diagram from the transfer function [10]. Since the state-variable representation is not unique, there are, theoretically, an infinite number of ways of writing the state equations. Analogous procedure may be followed for writing the discrete state equation from transfer function. The transfer function of single-input-single-output system of the form [10],

$$G(s) = \frac{a_{n-1}s^{n-1} + a_{n-2}s^{n-2} + \dots + a_1s + a_0}{s^n + b_{n-1}s^{n-1} + \dots + b_1s + b_0} \quad (1)$$

can be written, after introducing an auxiliary variable $E(s)$, as [10],

$$\frac{Y(s)}{U(s)} = G(s) = \frac{a_{n-1}s^{n-1} + a_{n-2}s^{n-2} + \dots + a_1s + a_0}{s^n + b_{n-1}s^{n-1} + \dots + b_1s + b_0} \frac{E(s)}{E(s)} \quad (2)$$

Another convenient and useful representation of the continuous system is the signal flow graph or the equivalent simulation diagram. These two forms can be derived, after dividing both the numerator and denominator of Equation (2) by s^n .

$$G(s) = \frac{Y(s)}{U(s)} = \frac{a_{n-1}s^{n-1} + a_{n-2}s^{n-2} + \dots + a_1s^{-n+1} + a_0s^{-n}}{1 + b_{n-1}s^{-1} + \dots + b_1s^{1-n} + b_0s^{-n}} \frac{E(s)}{E(s)} \quad (3)$$

From this expression we obtain two equations

$$Y(s) = (a_{n-1}s^{n-1} + a_{n-2}s^{n-2} + \dots + a_1s^{-n+1} + a_0s^{-n})E(s) \quad (4)$$

$$U(s) = (1 + b_{n-1}s^{-1} + \dots + b_1s^{1-n} + b_0s^{-n})E(s) \quad (5)$$

and Equation (4) can be rewritten in the form

$$E(s) = U(s) - b_{n-1}s^{-1}E(s) - \dots - b_1s^{1-n}E(s) - b_0s^{-n}E(s) \quad (6)$$

Equations (4) and (6) may be used to draw the signal flow graph shown in Fig 1, whose transfer function is given by Equation (1).

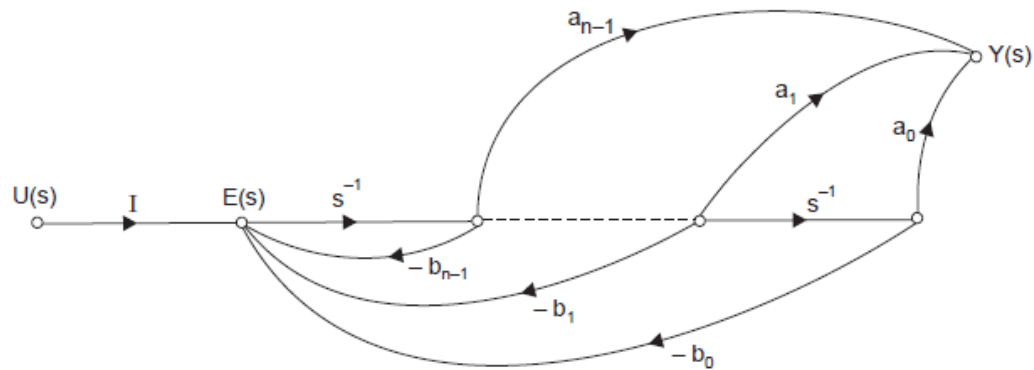

Figure 1: Signal flow graph representation of Equation (1)

In signal flow graph the term $s^{-1} = 1/s$ represents pure integration. The signal flow graph of Fig.1 can also be represented by the equivalent simulation diagram, with the states indicated as in Fig.2. Noting the structure of the signal flow graph in Fig.1 and its association with the numerator and denominator polynomials represented by Equations (4) and (5) respectively, it is apparent that the signal flow graph or simulation diagram can be obtained by inspection of the transfer function in Equation (1). The structure of Fig.1, together with Equations (4) and (5), is referred to as the phase variable canonical form of system representation.

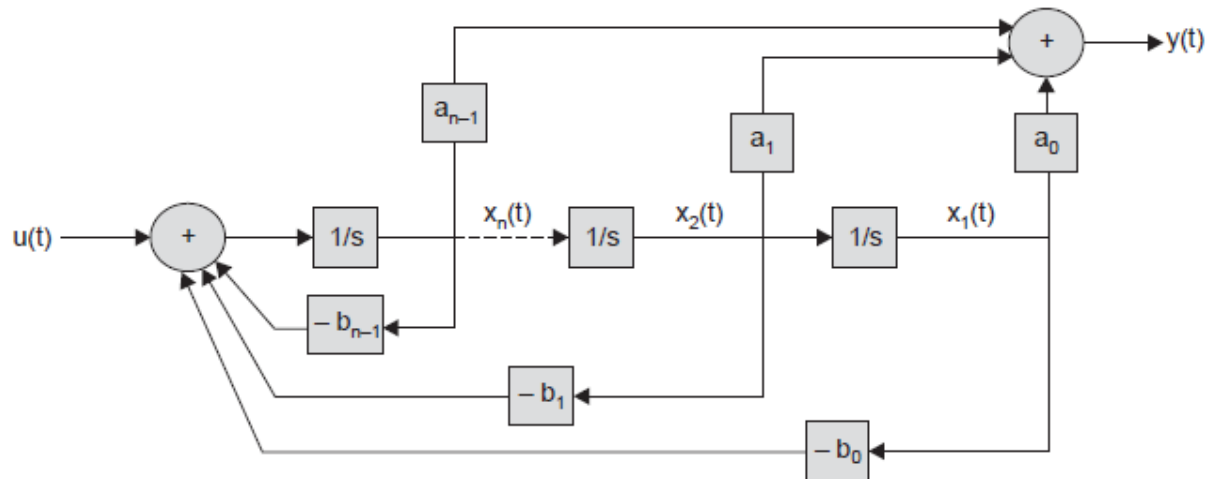

Figure 2: Simulation diagram equivalent to the signal flow graph in Fig. 3.5[10]

Another standard form called observer canonical form is shown in Fig. 3. The equivalence of the system in Fig. 3 to the Equation (1) may be established by computing the transfer function $Y(s)/U(s)$ from the figure.

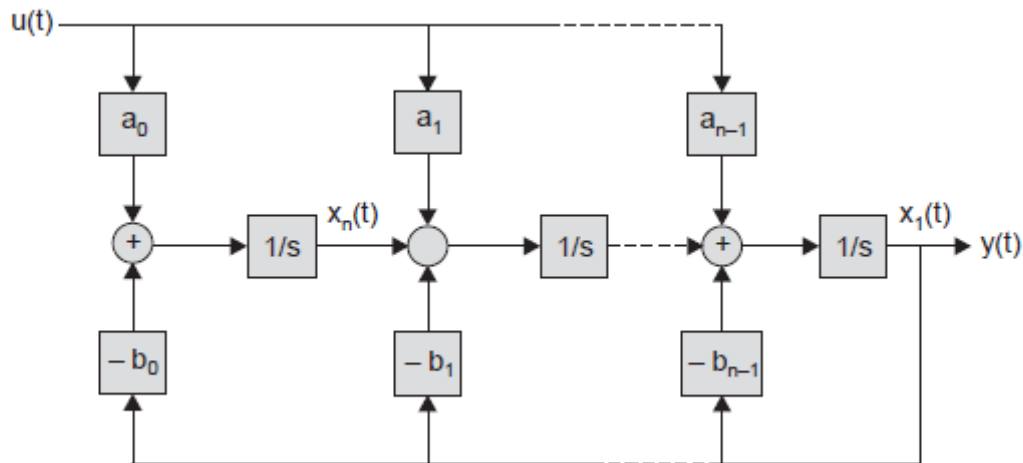

Figure 3: Observer Canonical Form

Open-loop system

The physical model for the DC Motor-Gear-Alternator assembly used in this study is shown in Figure 4

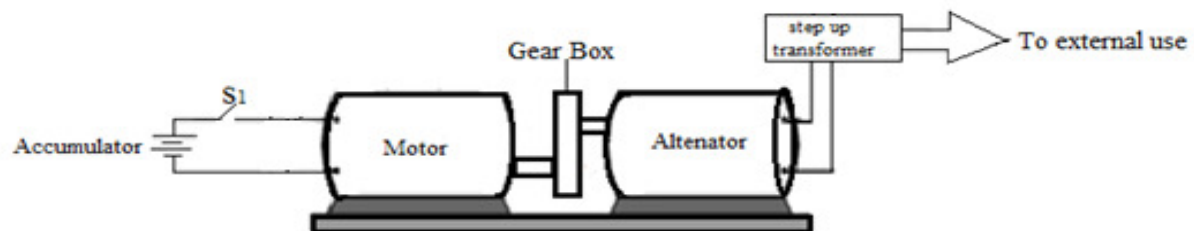

Figure 4: Physical model for the DC motor-gear-alternator.

The gear unit is introduced between the motor and the alternator as an amplifying system of any input parameter including voltage and current. The amplification power of the gear unit requires an establishment of the relationship between the gear ratio, the input voltage and the voltage output. This is primarily made possible by developing a mathematical model incorporating this correlation.

The schematic representation for the DC motor-gear-alternator set components is shown in Figure 5.

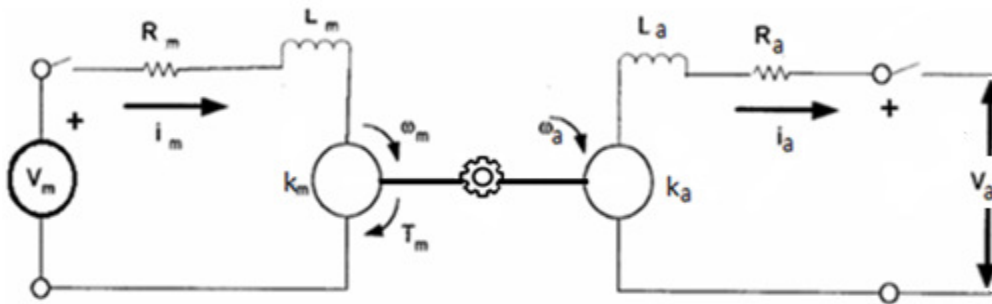

Figure 5: Schematic representation of the DC motor-gear-alternator

2.2 System equations

The mathematical model for DC motor-gear-alternator is found using Kirchhoff's voltage law[11], ohm's law [12] and Newton's second law of motion[13].

The electric circuit of the motor is shown in Figure 6

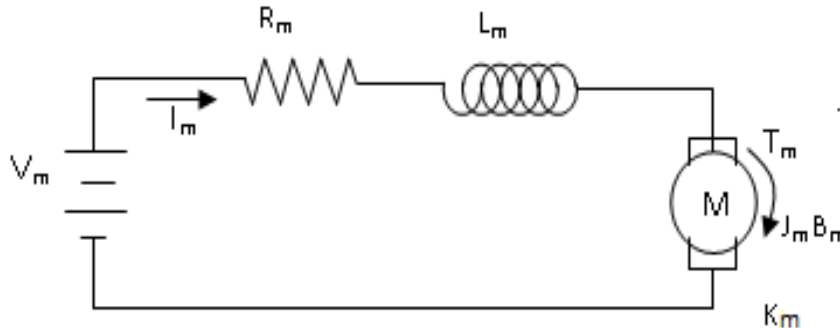

Figure 6: DC Motor model

In a more general case, inductance [14] is defined as

$$L = \frac{d\phi}{di} \quad (7)$$

Any change in the current through an inductor creates a changing flux, inducing a voltage across the inductor. By Faraday's law of induction, the voltage induced by any change in magnetic flux through the circuit is,

$$v = \frac{d\phi}{dt} \quad (8)$$

Substituting for $d\phi$ in (8), above using (7) yields,

$$v = \frac{d}{dt} (Li) = L \frac{di}{dt} \quad (9)$$

The voltage V of the motor is proportional to the angular velocity of the shaft by a constant factor k_e .

$$v = k_e \omega \quad (10)$$

Where k_e is the electrical constant, inherent to the motor, and ω is the angular velocity of the motor.

The current through the conductor can be obtained using Ohm's law. Ohm's law states that the current through a conductor between two points is directly proportional to the voltage across the two points. Introducing the constant of proportionality, the resistance, mathematical equation that describes this relationship is,

$$i = \frac{v}{R} \quad (11)$$

Where, i , is the current through the conductor, v , is the voltage measured across the conductor in units of volts, and R is the resistance of the conductor in units of ohms.

Applying Kirchoff's voltage law to the motor we obtain,

$$V_m(t) = R_m i_m(t) + L_m \frac{di_m}{dt}(t) + K_e \omega_m(t). \quad (12)$$

Whereas,

$$i_m = \frac{T_m}{k_t} \quad (13)$$

Where, V_m is the motor voltage, R_m is the armature resistance of the motor, i_m is the motor current, L_m is the inductance of the motor, k_t is the torque constant of the motor, ω_m is the motor angular velocity and T_m is the torque of the motor. For DC motors, the torque and electrical constants, k_e and k_t are equal

Taking the Laplace transform with zero initial condition, we obtain

$$V_m(s) = R_m \frac{T_m(s)}{K_m} + L_m s \frac{T_m(s)}{K_m} + K_m \omega_m(s) \quad (14)$$

The unbalanced torque on a body along axis of rotation determines the rate of change of the body's angular momentum,

$$T = \frac{dl}{dt} \quad (15)$$

Where \mathbf{l} is the angular momentum vector, T is the torque and t is time. For rotation about a fixed axis,

$$\mathbf{l} = J\omega \tag{16}$$

Where J is the moment of inertia and ω is the angular velocity. It follows that

$$\mathbf{T} = \frac{d\mathbf{l}}{dt} = \frac{d(J\omega)}{dt} = J \frac{d\omega}{dt} \tag{17}$$

The frictional force, F, is proportional to the object's velocity, \mathbf{u} , giving the relationship. $\mathbf{F} = -\mathbf{B}\mathbf{u}$, where \mathbf{B} is the frictional drag. Relating this equation to rotational motion results in

$$\mathbf{T} = -\mathbf{B}\omega \tag{18}$$

Torque, is proportional to the armature current i by a constant factor k_e as defined in (7)

$$\mathbf{T} = k_e i \tag{19}$$

Applying Newton's second law of motion, it follows that the torque, T, as defined in equation (17), (18) and (19) for a motor, m becomes;

$$J_m \frac{d\omega_m}{dt} = T - B_m \omega_m \tag{20}$$

Where, J_m is the moment of inertia of the motor and B_m is the viscous friction coefficients. Taking the Laplace transform with zero initial condition, we obtain,

$$\mathbf{T}_m = J_m s\omega_m(s) + B_m \omega_m(s) \tag{21}$$

Substituting into equation (14) we obtain,

$$\frac{\omega_m}{V_m} = \frac{K_m}{(R_m + L_m s)(J_m s + B_m) + K_m^2} \tag{22}$$

This is the transfer function for the motor.

Similarly, electric circuit of the alternator, a, is shown in Figure 7.

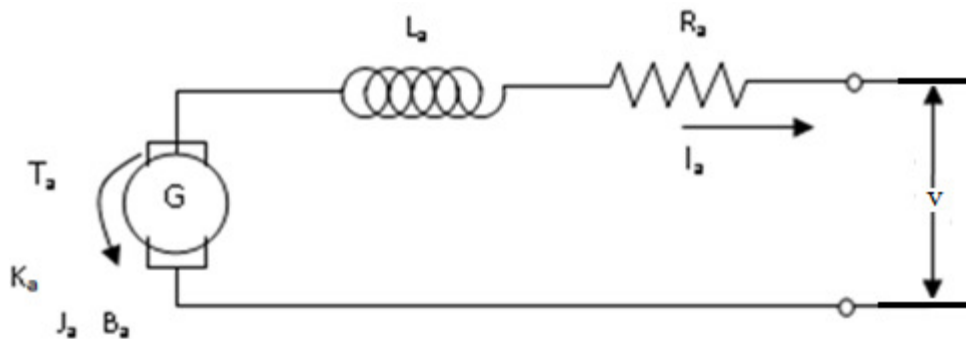

Figure 7: Alternator model

Applying Kirchhoff's voltage law, the voltage definition is similar to that of the motor, equation (12), but with alternator definitions as follows,

$$K_a \omega_a = R_a i_a(t) + L_a \frac{di_a}{dt}(t) + v_a(t) \quad (23)$$

Applying Newton's second law of motion, the torque, T, for the alternator as defined by equation (17), (19), (20) and (21) in Laplace domain we have,

$$\frac{V_a}{\omega_a} = \frac{K_a^2 - (R_a + L_a s)(J_a s + B_a)}{K_a} \quad (24)$$

Equation (24) gives the transfer function for the alternator.

For amplification purposes, a relationship between the motor and the alternator is achieved by introducing gears as the coupling unit for the motor-alternator assembly. The Figure 8 below is used to derive the relationship between voltage entering the motor, gear ratio and voltage leaving the alternator.

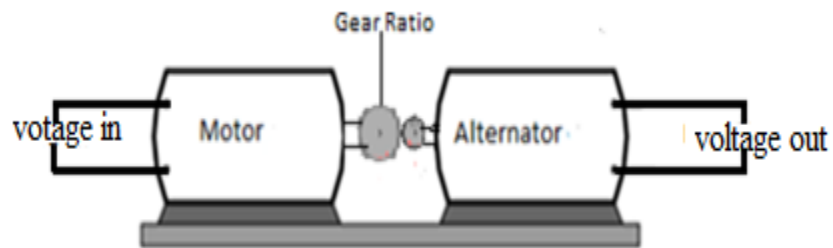

Figure 8: Voltage relationship

The gear ratio, G_r expresses the ratio of the frequency of the motor shaft to the frequency of the alternator shaft.

Thus, we can multiply the frequency f_m of the motor shaft (the input) with the gear ratio to find the frequency f_a of the alternator rotor (the output). We can calculate as follows,

$$f_a = G_r f_m \quad (25)$$

The relationship between angular speed of the shaft and the frequency [15] is given by

$$\omega = \frac{2\pi}{t} = 2\pi f, \quad (26)$$

Where, ω is the angular speed measured in radians per second, t is the period measured in seconds, f is the ordinary frequency measured in hertz.

The transfer function from the input armature voltage to the resulting voltage of the alternator is found by using equations, (22), (23), (25) and (26). We obtained the transfer function of the DC motor-gear-alternator system as

$$\frac{V_a}{V_m} = G_r \left[\frac{k_m k_a^2 - (J_a s + B_a)(R_a + L_a s)}{k_a (R_m + L_m s)(J_m s + B_m) + k_m^2} \right] \quad (27)$$

For this system k_m and k_a are approximately equal, hence,

$$\frac{V_a}{V_m} = G_r \left[\frac{k^2 - (J_a s + B_a)(R_a + L_a s)}{(R_m + L_m s)(J_m s + B_m) + k^2} \right] \quad (28)$$

or

$$G(s) = G_r \left[\frac{-J_a L_a S^2 - (J_a R_a + B_a L_a) S - (B_a R_a - k^2)}{J_m L_m S^2 + (J_m R_m + B_m L_m) S + (B_m R_m + k^2)} \right] \quad (29)$$

Equation (29) gives the transfer function of motor-gear-alternator system.

Simulink Model of the Motor-Gear- Alternator System

By implementing equations (29) in a block diagram, the Simulink model for the system shown in Figure 2 is obtained.

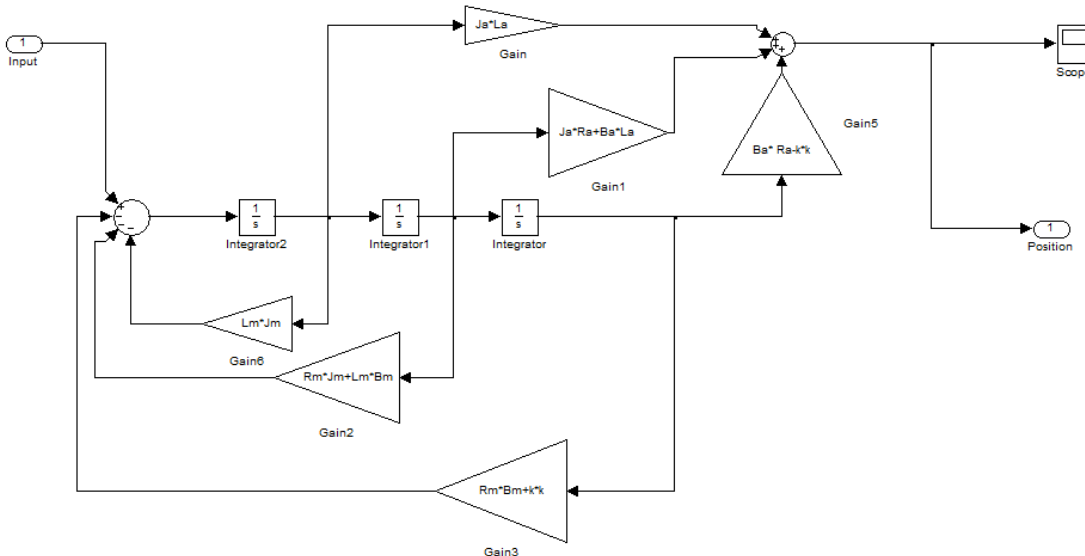

Figure 9: Simulink model of DC Motor-Gear- Alternator System

Now the model is complete. We simply need to supply the proper input and define the output of interest. The input to the system is the voltage supplied to the DC motor. The output of the system, which we will observe and ultimately try to control, will be the voltage of the alternator.

3.1 Running the model

The design parameters are the R_m armature resistance of the motor, R_a Armature Resistance of alternator, L_m inductance of the motor, L_a Inductance of the alternator, B_m viscous friction coefficients of the motor, B_a viscous friction coefficients of the alternator, K_m torque constant of the motor, K_a torque constant of the alternator and the

G_r gear ratio. Before running the model, we need to assign numerical values to each of the variables used in the model. For the MGA system, we assume the following values.

$$G_r = 1, L_a = 0.5, L_m = 0.5, B_a = 0.1, B_m = 0.1, R_a = 1, R_m = 1, J_a = 0.01, J_m = 0.01, k = 0.01$$

Results and discussion

Now, when the simulation is run the voltage output is as shown in figure 10. We can now easily compare the effect of different values of the parameters.

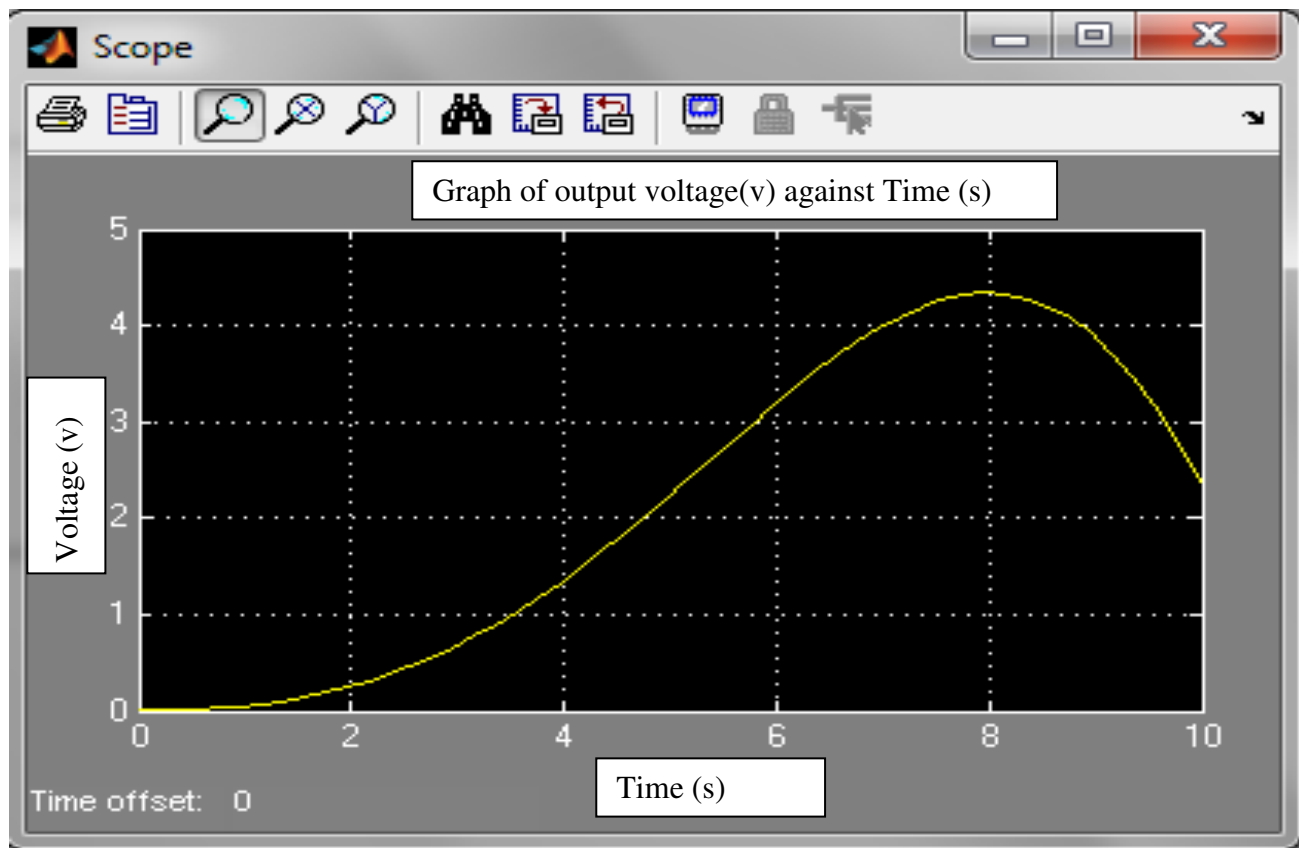

Figure 10 Voltage response of our model using the initial parameter values

Conclusion:

In this study, we derived the mathematical model for the system from first principles and then represented the derived equations within Simulink. The model is tested using some numerical values (assumed values). The results show that the output (voltage of the alternator) changes exponentially with time. There is work underway on parameter identification of the system and stability analysis of the MGA system for practical applications.

References

1. Ahameed, S.R., *Design of simple recycling ac electrical energy generation system with small dc input & high efficiency with good load handling capability*. 2014. **3**(2): p. 419-423.
2. Gieras, J.F., *Permanent magnet motor technology: design and applications*. 2002: CRC press.
3. Hinkelmann, K. and O. Kempthorne, *Design and Analysis of Experiments, Special Designs and Applications*. Vol. 3. 2012: John Wiley & Sons.
4. Basilio, J.C. and M.V. Moreira, *State-space parameter identification in a second control laboratory*. Education, IEEE Transactions on, 2004. **47**(2): p. 204-210.
5. Gardner, M., J.: *L. BARNES, Transients in Linear Systems, Vol. 1*. 1942, Wiley New York.
6. Pol, B.v.d. and H. Bremmer, *Operational Calculus based on the two-sided Laplace integral. By Balth. van der Pol and H. Bremmer*. 1950: University Press.
7. Saha, S., M.K. Ray, and P. Roy, *A Comparison between the Performance of Fuzzy Logic-based PD Controller and General PD Controller*. Copyrights© 2012 Votrix Publication 2012.
8. Zadeh, L.A., *Fuzzy sets*. Information and control, 1965. **8**(3): p. 338-353.
9. Bezdek, J.C., *A review of probabilistic, fuzzy, and neural models for pattern recognition*. Journal of Intelligent & Fuzzy Systems, 1993. **1**(1): p. 1-25.
10. Mandal, A.K., *Introduction to Control Engineering: Modeling, Analysis and Design*. 2006: New Age International.
11. Rashid, M.H., *Power electronics handbook: devices, circuits and applications*. 2010: Academic press.
12. Mayer, R.E., *Models for understanding*. Review of educational research, 1989. **59**(1): p. 43-64.
13. Newton, I., A. Motte, and F. Cajori, *Mathematical principles of natural philosophy*. 1987: W. Benton: Encyclopaedia Britannica.
14. Olson, H.F., *Dynamical analogies*. 1958: Van Nostrand Princeton, NJ.
15. *Understanding Physics*. 2006: Wiley India Pvt. Limited.
16. Wu, Z., et al., *A solar-powered traveling-wave thermoacoustic electricity generator*. Solar Energy, 2012. **86**(9): p. 2376-2382.
17. Perlman, H., *Hydroelectric power: How it works*. Hydroelectric Power: How It Works, USGS Water Science for Schools, 2013.
18. Shumway-Cook, A. and M.H. Woollacott, *Motor control: theory and practical applications*. 1995: Lippincott Williams & Wilkins.
19. Beaty, H.W. and J.L. Kirtley, *Electric motor handbook*. 1998: McGraw-Hill Professional.
20. Bell, R. and K.J. Åström, *Dynamic models for boiler-turbine-alternator units: data logs and parameter estimation for a 160 MW unit*. 1987: Lund Institute of Technology, Department of Automatic Control.
21. Vas, P., *Sensorless vector and direct torque control*. 1998: Oxford Univ. Press.

DEFINITION, ACRONYMS AND ABBREVIATIONS

ODE: Ordinary Differential Equation

DC: Direct Current

AC: Alternating Current

- R_m Armature Resistance of the Motor
 R_a Armature Resistance of alternator
 i_m Motor current
 i_a Alternator current
 V_m Motor Voltage
 V_a Alternator Voltage
 L_m Inductance of the motor
 L_a Inductance of the alternator
 J_m Moment of inertial of motor
 J_a Moment of inertial of alternator
 θ_m Angular displacement of motor
 θ_a Angular displacement of alternator
 ω_m Motor angular velocity
 ω_a Alternator angular velocity
 T_m Torque of motor
 T_a Torque of alternator
 B_m Viscous friction coefficients of the motor
 B_a Viscous friction coefficients of the alternator
 K_m Torque Constant of the motor
 K_a Torque Constant of the alternator

DEFINITION OF TERMS

Electricity Generation

Electricity generation is the process of generating electrical power from other sources of primary energy [16].

Turbines are used to spin the magnets inside the generator and different kinds of power plants get that energy from different sources. In a hydroelectric station, falling water is used to spin the turbine, in nuclear stations and in thermal generating stations powered by fossil fuels, steam is used. A wind turbine uses the force of moving air. Figure below is an example of such a generator.

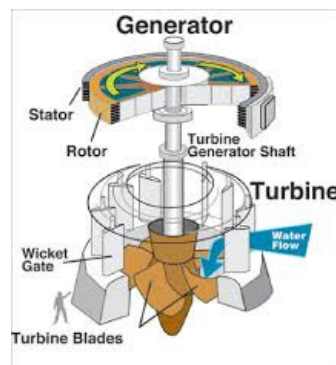

Figure 11: Hydroelectric turbine generator[17]

The fundamental principles of electricity generation were discovered during the 1820s and early 1830s by the British scientist Michael Faraday. His basic method is still used today. Electricity is generated by the movement of a loop of wire, or disc of copper between the poles of a magnet.

Motor

A motor is an electrical machine that converts electrical energy into mechanical energy [18]. The first electric motors were simple electrostatic devices created by the Scottish monk Andrew Gordon in the 1740s. The theoretical principle behind production of mechanical force by the interactions of an electric current and a magnetic field, Ampere's force law, was discovered later by André-Marie Ampere in 1820 [19].

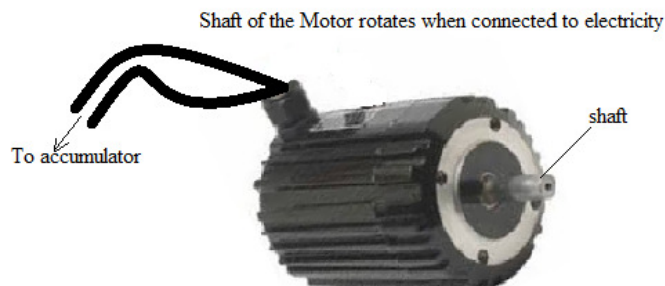

Figure 12: DC motor[17]

Alternator

An alternator is an electrical generator that produces alternating current [20]. Dynamos were the first electrical generators capable of delivering power for industry, and the foundation upon which many other later electric power conversion devices were based, including the electric motor, the alternating-current alternator, and the rotary converter. Today, the simpler alternator dominates large scale power generation, for efficiency, reliability and cost reasons.

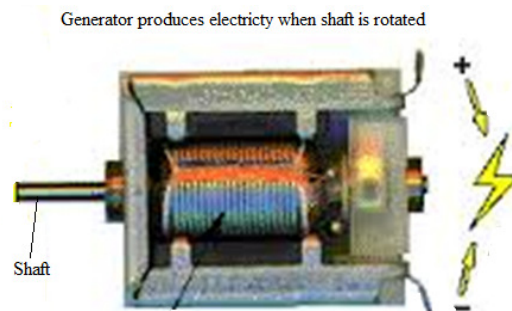

Figure 13: Alternator**Torque**

Torque is a measure of the tendency of a force to rotate an object about some axis [21].

$$\mathbf{Torque = Force \times Distance} \quad (30)$$

The SI unit of force is the newton, and the unit of distance is meters. Since torque is the product of force and distance, the unit of torque is newton-metres.

Newton's Second law

Newton's Second Law states that the acceleration of an object is directly proportional to the net force acting on it, and inversely proportional to its mass [21]. This can be expressed by the equation,

$$\mathbf{F = ma} \quad (31)$$

Gear Ratios and Torque

The gear ratio, G_r , is the ratio of the number of teeth on the output gear to the number of teeth on the input gear [21]. The gear ratio expresses the ratio of the output torque to the input torque. Thus, we can multiply the torque supplied at the motor shaft (the input) by the gear ratio to find the torque at the alternator axle as follows,

$$\mathbf{Alternator Torque = Motor Torque \times G_r} \quad (32)$$